



Curriculum Aligned Competency Based Test Items Mathematics Class - 10

Central Board of Secondary Education

Acknowledgements

Patrons

- Shri Dharmendra Pradhan, Minister of Education, Government of India.
- Dr. Rajkumar Ranjan Singh, Minister of State for Education, Government of India.
- Smt. Annpurna Devi, Minister of State for Education, Government of India.
- Dr. Subhas Sarkar, Minister of State for Education, Government of India.
- Ms. Anita Karwal, IAS, Secretary, Department of School Education and Literacy, Ministry of Education, Government of India.

Advisory Inputs

- Sh. Manoj Ahuja, IAS – We express our gratitude for his guidance in the development of this resource material during his tenure as Chairman, Central Board of Secondary Education.
- Dr. Vineet Joshi, IAS, Chairman, Central Board of Secondary Education.

Guidance and Support

- Dr. Joseph Emmanuel, Director (Academics), Central Board of Secondary Education.

Co-ordination

- Dr. Sweta Singh, Joint Secretary (Academics), Central Board of Secondary Education.

Content Development

- Sri Aurobindo Society, New Delhi
- Australian Council for Educational Research (ACER), New Delhi.

Content Review

- Dr. Sweta Singh, Joint Secretary (Academics), Central Board of Secondary Education.
- Ms. Anjali Chhabra, Deputy Secretary, Central Board of Secondary Education.
- Teachers of:
 - Delhi Public School, Sector 40, Chandigarh
 - St John's High School, Sector 26, Chandigarh
 - DAV Model School, Sector 15, Chandigarh

Curriculum Aligned Competency Based Test Items

Class 10

Foreword

The National Education Policy (2020), Government of India, envisions transforming school education by equipping students with 21st century skills. The endeavour is to shift focus from rote-learning to acquisition of competencies with a resolve to make education more meaningful and relevant.

The Central Board of Secondary Education (CBSE) in its continuous endeavour to improve the quality of education has already introduced some initiatives in this direction. Strengthening these efforts, the Board had signed an MoU with Sri Aurobindo Society (SAS), Pondicherry in November 2019. As a part of this initiative, SAS is supporting CBSE to develop resource materials, train teachers and take other measures that would facilitate adoption of Competency Based Education in schools. SAS has engaged with Australian Council for Educational Research (ACER) as its knowledge partner for this project.

CBSE, in collaboration with SAS and ACER, has prepared this resource material- ***Curriculum Aligned Competency Based Test Items (Class 10)*** in February, 2022 which is a compilation of assessment items in Mathematics that are aligned to the NCERT/CBSE curriculum. These tasks based on authentic real life situations focus on developing critical understanding among learners in the discipline. Each test covers about 10 questions from a chapter. The assessments, useful for students' practice, are also exemplars for teachers who with their ingenuity can develop many similar items.

— Team CBSE

About CBSE

The Central Board of Secondary Education (CBSE) is a national Board under the Ministry of Education, Government of India. The Board has more than 27,000 schools affiliated to it in India and overseas, in 25 countries. These include the Kendriya Vidyalayas, the Jawahar Navodaya Vidyalayas, Central Tibetan Schools, schools run/aided by the State Governments and private schools. The Board's mission is to encourage quality of education focussed on holistic development of learners. It motivates schools and teachers to adopt learner centric enquiry-based pedagogies and use innovative methods to achieve academic excellence. The Board is committed to providing a stress-free learning environment to develop competent and confident students who emerge as enterprising citizens of tomorrow, promoting harmony and peace in the world.

About SAS

Sri Aurobindo Society (SAS) is an international, spiritual, and cultural, not-for-profit NGO. SAS has been recognised by the Government of India as a Charitable Organisation, a research institute and an institute of national importance. Sri Aurobindo Society has more than 300 centres and branches across the country, with its head office in Puducherry. SAS is setting up models, centers of excellence and training institutions that are sustainable, scalable and replicable in the country.

About ACER

Australian Council for Educational Research (ACER) is a leading and pioneer international organization working in the field of competency based learning. ACER has been instrumental in coordinating a consortium of international organizations for the implementation of the Programme for International Students Assessment survey in 2000, 2003, 2006, 2009 and 2012.

Table of Contents

► Test Item

1	Real Numbers	03
2	Polynomials	06
3	Pair of Linear Equations in Two Variables	09
4	Quadratic Equation	12
5	Arithmetic Progression	15
6	Traingles	18
7	Coordinate Geometry	21
8	Introduction to Trigonometry	24
9	Some Applications of Trigonometry	28
10	Circle	32
11	Constructions	36
12	Areas related to circle	41
13	Surface Area and Volume	46
14	Statistics	50
15	Probability	54

► Scoring Key

1	Real Numbers	59
2	Polynomials	62
3	Pair of Linear Equations in Two Variables	66
4	Quadratic Equation	70
5	Arithmetic Progression	74
6	Traingles	77
7	Coordinate Geometry	81
8	Introduction to Trigonometry	85
9	Some Applications of Trigonometry	89
10	Circle	92
11	Constructions	95
12	Areas related to circle	98
13	Surface Area and Volume	101
14	Statistics	104
15	Probability	107

Curriculum Aligned Competency Based Test Items

Mathematics

Class 10 – Chapter 1

Real Numbers

Aadya has 143 stamps; she gives away 11 stamps and divides the remaining equally into groups. Sumit has 220 stamps; he gives away 11 stamps and divides the remaining equally into groups. They end up with the same number of groups.

SAS21M10Q0101

- 1 What is the number of groups?

SAS21M10Q0102

- 2 What is the number of stamps in Adya's and Sumit's groups?

SAS21M10Q0103

- 3 A number is multiplied by 5. Then, 40 is subtracted from the product. The result obtained is then multiplied by 2 and 50 subtracted from the product so obtained. The answer is a two-digit number. What is the largest integer that can be used to get a two-digit number as the answer?

Richa is an artificial jewellery seller. She buys them from a dealer at a price based on the presence or absence of stones as shown in the table below.

Item	With stones	Without stones
Ring	110	70
Earring pair	170	90
Bangle pair	90	120

SAS21M10Q0104

- 4 For every ring with stones, two rings without stones are purchased by Richa's customers. Richa buys rings accordingly from the dealer for Rs 10 000. How many rings does she buy?

SAS21M10Q0105

- 5 In her next visit to the dealer, Richa finds that dealer has increased the price of rings with stones by Rs 10. Richa still wants to spend Rs 10 000 on rings. What is the reduction in the number of rings she buys?

- A. 10
 B. 20
 C. 40
 D. 50

SAS21M10Q0106

- 6 The dealer increases the price of one type of earrings. Richa buys earrings (with stones and without stones) in the ratio of 5:9 before the price hike. After the price hike, she buys earrings in the ratio of 8:13 with the same amount of money. Does she buy more earrings with stones than earrings without stones after the price hike? Give reasons.

SAS21M10Q0107

- 7 Richa purchases 37 pairs of bangles with stones and 33 pairs of bangles without stones. She divides them into two sets. Set 1 contains 40 pairs of bangles, and set 2 contains 30 pairs of bangles. What is the difference between the number of bangle pairs with stones in set 1 and the number of bangle pairs without stones in set 2?

- A. 4
 B. 7
 C. 10
 D. 30

SAS21M10Q0108

- 8** Despite the price hike by the dealer, Richa increases the number of jewellery with stones she purchases for her customers. What could be the reason for her decision?

Kartik is a salesman of mobile phones. His yearly target is to sell a fixed number of mobile phones in a year. He planned to meet $\frac{6}{11}$ of his yearly target by selling the phones during a festive month. He could only meet $\frac{6}{11}$ of his target for the festive month. He now has to meet the remaining target for the month and sell 425 more mobile phones to meet his yearly target.

SAS21M10Q0109

- 9** Approximately what percentage of the yearly target was met during the festive month?

SAS21M10Q0110

- 10** How many units of the mobile phones did Kartik have to sell to meet his yearly target?

Curriculum Aligned Competency Based Test Items

Mathematics

Class 10 – Chapter 2

Polynomials

Amit designs a flower vase using a graph of polynomial equations. Equation of the curve l is given in the graph.

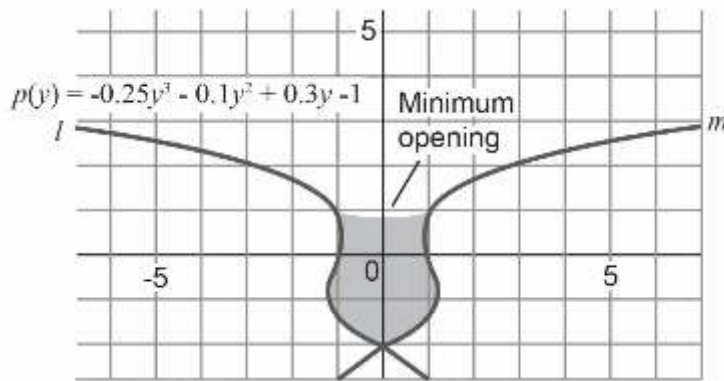

SAS21M10C0201

- 1 Sara looks at the graphical model and makes an observation, “The zero of the polynomial is at the origin.” Is she correct? If not, what are the coordinates of the zero of the polynomial

SAS21M10C0202

- 2 The curve m is a mirror image of $p(y)$ on the y axis. Which polynomial represents curve m ?

- A. $p(y) = -0.25y^3 - 0.1y^2 + 0.3y - 1$
 B. $p(y) = -0.25y^3 - 0.1y^2 - 0.3y - 1$
 C. $p(y) = 0.25y^3 + 0.1y^2 - 0.3y + 1$
 D. $p(y) = 0.25y^3 + 0.1y^2 - 0.3y$

SAS21M10C0203

- 3 Sara changes the coefficient of y^3 in the polynomials for the curves l and m . How does it affect the shape of the flowerpot?

SAS21M10C0204

- 4 Amit wants to decrease the minimum opening of the flower pot. Which term of the polynomials for the curves l and m should he change?

Ajit uses a cardboard sheet of 30 cm \times 40 cm to design a box. He marks four squares of equal size with side length x cm to draw the net of the open box.

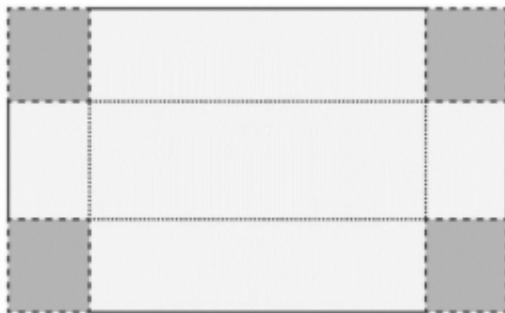

SAS21M10C0205

- 5 Ajit folds the net to make an open box. What will be the volume of the open box?

SAS21M10C0206

- 6 Ajit decides that the height of the box should be lesser than its length and width. What are the possible range of values for x ?

A graph of a cubic polynomial is plotted on a graph paper.

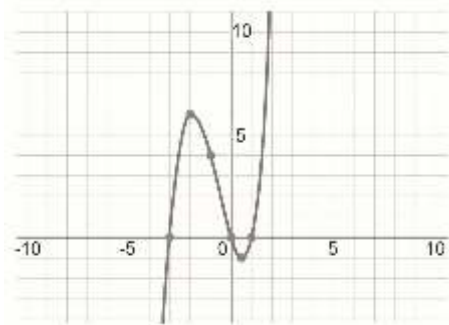

SAS21M10C0207

- 7 What is the sum of the roots of the polynomial?

SAS21M10C0208

- 8 The graph of a polynomial shows it is extended on both sides. What does it indicate about the values of the y coordinate?

SAS21M10C0209

- 9 A quadratic polynomial has integral roots. The sum of its roots is 7. Which of the following cannot be the constant term of the polynomial?

- A. 6
- B. 10
- C. 12
- D. 14

SAS21M10C0210

- 10 A polynomial is given by $p(x) = x^3 - 2x^2 + \frac{3}{4}x$
For what values of x is the polynomial $p(x) = 0$?

Curriculum Aligned Competency Based Test Items

Mathematics

Class 10 – Chapter 3

Pair of Linear Equations in Two Variables

Tickets for a play can be booked online as well as purchased from the theatre. A 10% discount is available on online ticket purchase. Simran likes to watch plays. She purchased the ticket online for a play. The ticket and food cost her Rs 600. The cost of food was one-third the cost of the ticket.

SAS21M10C0301

- 1 Represent the relation between the cost of the ticket and the cost of food for Simran algebraically. Also represent the relation between the cost of the ticket and the cost of food for Simran and money spent algebraically.

SAS21M10C0302

- 2 Simran purchased the ticket for a musical play from the theatre. How much can she spend on food in Rs 600?

SAS21M10C0303

- 3 A group of friends went to watch a play. Some of them purchased tickets online and some bought them at the theatre. If two more had purchased online tickets the total ticket price would be Rs 100 less. Is this true for any group greater than 2? Why?

SAS21M10C0304

4 In the theatre canteen, two packets of popcorn and a mango drink cost Rs 330. One packet of popcorn and two mango drinks cost Rs 300. What is the cost of the packet of popcorn?

- A. 100
- B. 120
- C. 150
- D. 200

Large cargo ships ferry cargo between ports. They take months to ferry them from one port to another. The distance in the sea is calculated in nautical miles (nm). The map shows the eastbound (grey) and westbound (black) cargo lines of a shipment company.

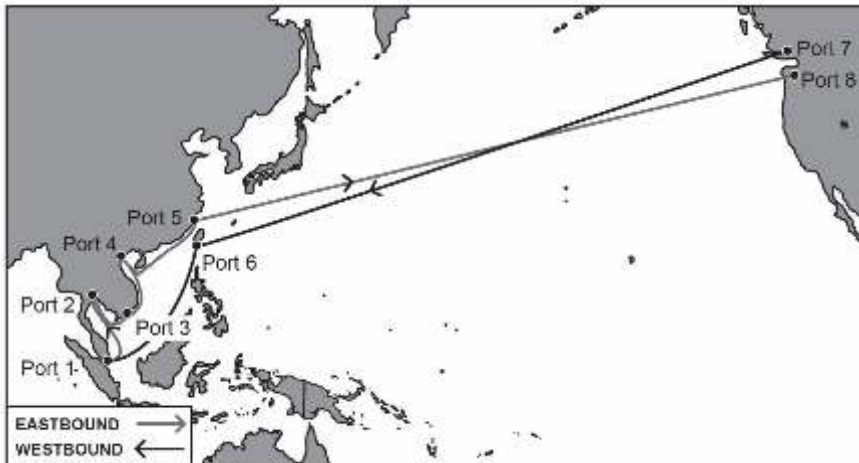

The distance between port 6 and port 7 is approximately 20 000 nm and a ship takes 95 days to travel between the ports in either direction.

The distance-time graph drawn by Pooja shows the journey of eastbound and westbound ships.

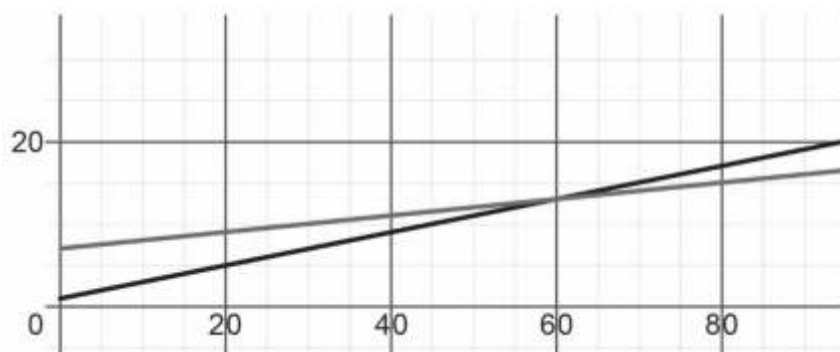

SAS21M10C0305

5 What do the two axes in the graph show?

SAS21M10C0306

- 6 According to Pooja's graph, what is the approximate distance travelled by the eastbound ship during these 95 days?

SAS21M10C0307

- 7 Anish looks at the graph and claims that an eastbound ship route meets the westbound route at 13000 nm. Is he correct? Give reasons.

SAS21M10C0308

- 8 The eastbound and westbound journeys are of different length in 95 days. What can be the possible reason for it?

Given below is a pair of linear equations.

$$4x + y = 8$$
$$4x - 2y = 16$$

SAS21M10C0309

- 9 Is the given pair of equations consistent? Justify your answer.

SAS21M10C0310

- 10 Does $x = 3$ and $y = -4$ satisfies the pair of linear equations?
Justify your answer.

Curriculum Aligned Competency Based Test Items

Mathematics

Class 10 – Chapter 4

Quadratic Equations

Digital images consist of pixels. A pixel can be considered as the smallest unit on a display screen in a mobile or a computer. The number of pixels, their size and colours depend on the display screen and its graphic card. Display screens are rectangular in shape and their size is defined as the length of the diagonal.

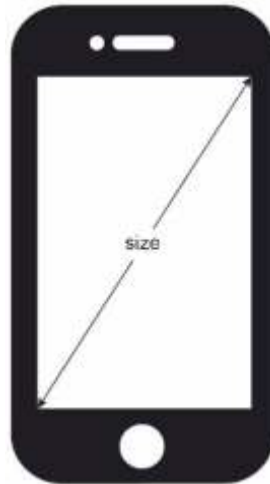

Amit is designing a web page for a display on a screen whose size is 1000 pixels.
The width of the screen is 800 pixels.

SAS21M10C0401

1 Which of the following equation can be used to calculate the height (h) of the screen?

- A. $h^2 + 200 \times 1800 = 0$
- B. $h^2 - 200 \times 1800 = 0$
- C. $h^2 - 200 = 0$
- D. $h^2 - 1800 = 0$

SAS21M10C0402

- 2** The size of a screen display can be measured in inches also. Is it possible to have a screen of size 13 inches where the width is 7 inches more than height? Give an example to justify.
-
-

SAS21M10C0403

- 3** The size of a screen is an important factor in designing a web page. The page can be opened on different screen sizes but during the initial designing stage, one screen area is considered as the safe area. The content in the safe area can be viewed without horizontal and vertical scrolling of the web page. The safe area of a web page is 40 pixels less than the width and 190 pixels less than the height of the display screen. Which of the following expression represents the safe area for the screen whose screen height is 200 pixels less than the screen width (w)?

- A. $w^2 - 50w + 400$
B. $w^2 - 350w + 30400$
C. $w^2 - 430w + 15600$
D. $w^2 - 200w + 7600$

SAS21M10C0404

- 4** Which of the following is not a method of solving a quadratic equation?
- A. Factorisation
B. Completing the square
C. Using quadratic formula
D. Identifying the nature of the root

Given below is the conversation between Gayatri and a mason.
Gayatri: 'Here are some 90 cm × 90 cm tiles. I want to use these in flooring of our courtyard.'
Mason: 'If I use all of these tiles, there will be four more columns than rows.'
Gayatri: 'I want to make a square floor.'
Mason: 'Either some tiles will be left unused or 35 additional tiles are required.'
Gayatri: 'I do not think 35 additional tiles are required to make a square courtyard.'
Mason: 'Okay, that is possible, but you still have to buy some more.'

SAS21M10C0405

- 5** How many tiles did Gayatri have?
-
-

SAS21M10C0406

- 6 What is the minimum number of tiles she has to purchase to make a square courtyard?

SAS21M10C0407

- 7 For the minimum number of tiles purchased, what can be the side length (in m) of the square courtyard?

Under a relief scheme, Rs. n^2 was distributed among 'n' number of people. The first beneficiary received Re. 1 plus $\frac{1}{n+1}$ of the remaining amount. The second beneficiary received Rs. 2 plus $1\frac{1}{n+1}$ of the remaining amount. The third beneficiary received Rs. 3 plus $1\frac{1}{n+1}$ of the remaining amount. The distribution is done in the same pattern for all the beneficiaries.

SAS21M10C0408

- 8 Which of the following expression represents money received by the first beneficiary?

A. $1 + \frac{1}{n} (n^2 - 1)$

B. $1 + \frac{1}{n} \times n^2$

C. $1 + \frac{1}{(n+1)} \times n$

D. $1 + \frac{1}{(n+1)} (n^2 - 1)$

SAS21M10C0409

- 9 Who do you think will get the maximum amount?

SAS21M10C0410

- 10 Is the distribution of the relief fund fair? Justify your answer.

Curriculum Aligned Competency Based Test Items

Mathematics

Class 10 – Chapter 5

Arithmetic Progressions

Stadium seating surrounds the centre pitch. Each row in the seating is positioned at a slightly higher level than the one in front of it. A safe seating-standing section of a stadium is shown in the figure below.

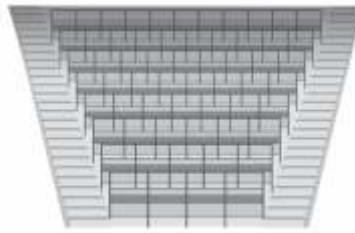

There are 20 rows in the section. Each row in the section is 700 mm in height, excluding the seat and has one more seat than the previous row, starting from the second row. The first row has 4 seats.

SAS21M10C0501

- 1 Sidharth is seating in the centre seat of Row 12 in the section. How many seats are on his left?

- A. 5
- B. 7
- C. 8
- D. 24

SAS21M10C0502

- 2 What is the seating capacity of the section?

- A. 80
- B. 210
- C. 270
- D. 840

Sam is standing in Row 15 and Ronit is standing in Row 1.



SAS21M10C0503

3 How much higher is Sam's row than Ronit's?

SAS21M10C0504

4 The height of the section is measured from the foot of the first row to the last row. What is the height of the section?

A chair is available in two models – with arms and without arms. A person bought 20 chairs of each model. After use, he stacked the chairs in a storeroom. The height of the storeroom is 1.55 m. The dimensions of the chair and how they are stacked is shown in the figure below.

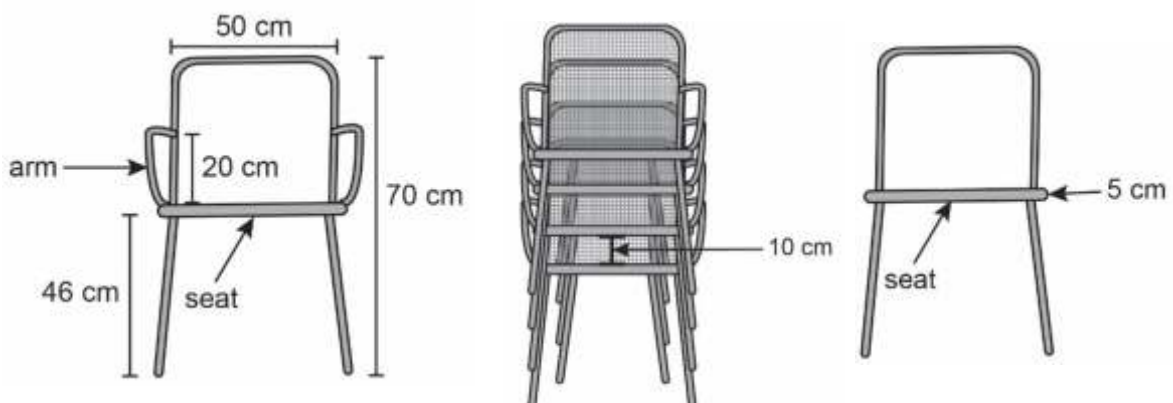

The dimensions of the seat (in cm) is $50 \times 40 \times 5$.

SAS21M10C0505

5 What is the height of the stack shown in the figure?

- A. 30 cm
- B. 76 cm
- C. 100 cm
- D. 110 cm

SAS21M10C0506

6 What is the maximum number of chairs with arms that can be stacked in the storeroom?

- A. 4
- B. 8
- C. 9
- D. 10

SAS21M10C0507

7 What is the maximum number of chairs without arms that can be stacked in the storeroom?

SAS21M10C0508

8 What is the minimum number of columns (stacks) in which all chairs can be stacked in the storeroom?

SAS21M10C0509

9 What can be the dimension of the storeroom (in m)?

- A $0.3 \times 1.5 \times 1.55$
- B $0.4 \times 1.75 \times 1.55$
- C $0.5 \times 0.4 \times 1.55$
- D $1 \times 2.75 \times 1.55$

SAS21M10C0510

10 What cannot be the difference between four consecutive terms of an arithmetic progression?

- A. 0, 0, 0
- B. -2, -2, -2
- C. 2, 3, 4
- D. $\frac{2}{7}, \frac{2}{7}, \frac{2}{7}$

Curriculum Aligned Competency Based Test Items

Mathematics

Class 10 – Chapter 6

Triangles

Some concrete water towers have been built to supply water to the localities nearby. They are usually mounted with a cylindrical tank. A water tower for a locality is 40 m high.



SAS21M10S0601

- 1 The water tower cast a shadow of 25 m. At the same time, a tree near it casts a shadow of 5 m. What is the height of the tree?
- A. 3.12 m
 - B. 8 m
 - C. 20 m
 - D. 25 m

SAS21M10S0602

- 2 A scale model of the water tower of 100 cm height is created. The height of its pillars is 75 cm each. What is the height of a pillar (in m) in the actual water tower?
- A. 7.5
 - B. 25
 - C. 30
 - D. 53.4

SAS21M10S0603

- 3** Dharmendra made a scale model of a water tower for another locality. The radius of the reservoir in the model is 6 cm and its volume is 216 cm^3 . The radius of the actual water reservoir is 2.5 m. What is its volume?

Three villages X, Y and Z are situated at the three ends of a triangular region bounded by three roads. The lengths of the roads connecting X to Y, Y to Z and Z to X are in the ratio 5:3:4. The total lengths of the three roads are 180 km.

A new road is to be constructed parallel to the longest road. A team of three researchers Mayank, Biju and Shanti work on the technical specifications of the new road construction. Each of them makes a scale drawing of the region using different scale factors.

SAS21M10S0604

- 4** Which types of triangles are included in their scale drawings, similar or congruent? Why

SAS21M10S0605

- 5** The proposed road will meet the road between Y and Z in the middle. How far is the village Y (in km) from the meeting point of the roads?

SAS21M10S0606

- 6** In all the three scale drawings, the actual length of the new road is provided. Would the road length be the same in their maps? Justify your answer.

A dollhouse with a triangular roof is shown below. The front and back triangles are equilateral triangles with side lengths 45 cm each. Panels parallel to the floor of the dollhouse are used to make the attic. The sides DE and GF of the panels divide the sides AB and AC into three equal parts.

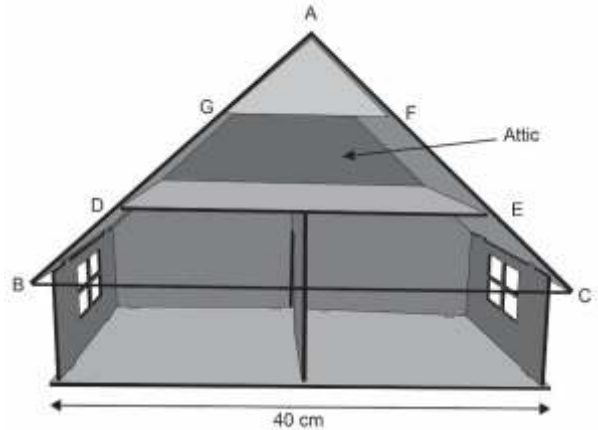

SAS21M10S0607

7 Which criteria of similar triangles do not apply to triangles AGF and ADE?

- A. AAA
- B. SSS
- C. SAS
- D. RHS

SAS21M10S0608

8 The area of triangle ABC is 692 cm^2 . What is the area of the plank AGF?

SAS21M10S0609

9 What is the height (in cm) of the attic?

SAS21M10S0610

10 Two overlapping right triangles are shown below.

What is the value of 'x'?

- A. 4 cm
- B. $5\sqrt{3}$ cm
- C. 10 cm
- D. 37.5 cm

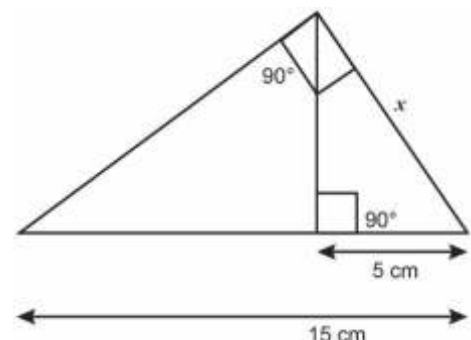

Curriculum Aligned Competency Based Test Items

Mathematics

Class 10 – Chapter 7

Coordinate Geometry

Ronit is the captain of his school football team. He has decided to use a 4-4-2-1 formation in the next match. The figure below shows the positions of the players in a 4-4-2-1 formation on a coordinate grid.

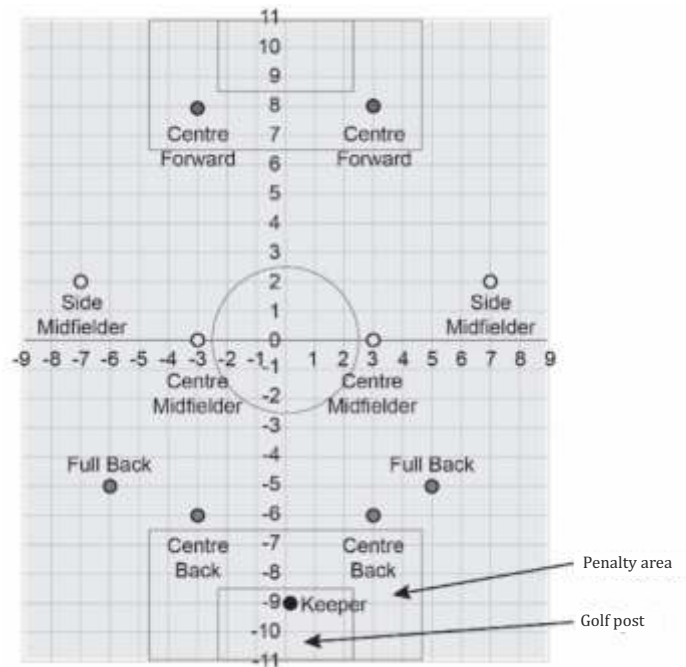

One square box represents 1 square unit.

SAS21M10S0701

1 Which of the following coordinates represents the position of the goalkeeper?

- A. (9, -9)
- B. (0, 9)
- C. (-9, 0)
- D. (0, -9)

SAS21M10S0702

2 What is the distance between the two centre forward positions in Ronit's plan?

- A. 3 units
- B. 6 units
- C. $5\sqrt{2}$ units
- D. 16 units

SAS21M10S0703

3 Mention two positions which are not equidistant from any axis.

SAS21M10S0704

4 Which two positions are on the line $2.5y - x - 11 = 0$?

SAS21M10S0705

5 What is the area (in square units) of the football field enclosed by the lines joining the two centre back positions and the goalkeeper's position?

- A. 0 square units
- B. 10.5 square units
- C. 24 square units
- D. 110.25 square units

SAS21M10S0706

6 A ball hit from the left full back position travels uninterrupted to the right centre forward position. What can be the minimum distance travelled by the ball?

- A. 22 units
- B. $\sqrt{178}$ units
- C. $5\sqrt{10}$ units
- D. 250 units

SAS21M09S0907

7 What is the area of the middle circle?

SAS21M09S0908

- 8** A ball hit from the left centre midfielder position touches the point (2, 11). Does the ball enter the goal post? Justify your answer.

SAS21M10S0709

- 9** What are the coordinates of the point on the y-axis which is equidistant from the left centre forward and the right centre midfielder positions?

- A. (0, 0)
- B. (0, 2)
- C. (0, 4)
- D. (0, 8)

SAS21M10S0710

- 10** What is the measure of the penalty area for one team?

- A. 10 m^2
- B. 17 m^2
- C. 25 m^2
- D. 29.25 m^2

Curriculum Aligned Competency Based Test Items

Mathematics

Class 10 – Chapter 8

Introduction to trigonometry

In the given figure, ABC, ADE, and AQP are three right triangles.

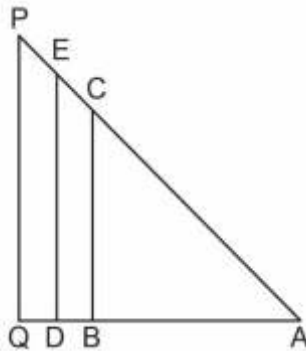

SAS21M10S0801

- 1 The value of $\sin A$ is the greatest for triangle PQA. Do you agree? Justify your answer.

SAS21M10S0802

- 2 ABC is an isosceles right triangle, right-angled at B. What is the value of $2 \sin A \times \cos A$?

- A. $\frac{1}{2}$
- B. 1
- C. $\frac{3}{2}$
- D. 2

SAS21M10S0803

3 Which one of the following statements is true about trigonometric ratios in a right triangle?

- A. The values of cot and tan vary from 0 to 1.
- B. The values of sin and cos vary from 0 to 1.
- C. The values of cos and sec vary from 0 to 1.
- D. The values of sin and cosec vary from 0 to 1.

A moving camera at the top of a 4 m high building captures the images of a walking man at five different positions. The five positions are shown in the figure below.

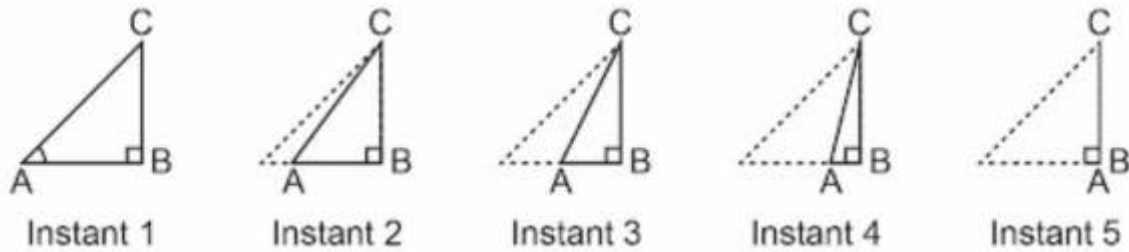

SAS21M10S0804

4 Describe the change in the value of $\sin A$.

SAS21M10S0805

5 Which of the following is not true for position 5?

- A. $AB = 0$
- B. $BC = AC$
- C. $BC = 1$
- D. $CA = AB$

SAS21M10S0806

6 In the isosceles triangle ABC, BD is the altitude and $\angle ABC = 120^\circ$.
What is the value of $\cos C$?

In the figure given below, PQRS is a quadrilateral. PR is perpendicular to QR and PS.

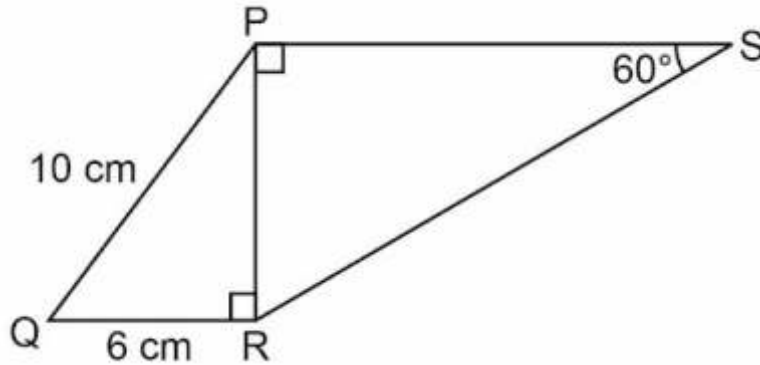

SAS21M10S0807

7 What is the value of $\tan Q$?

- A. $\frac{3}{5}$
- B. $\frac{1}{2}$
- C. 1
- D. $\frac{4}{3}$

SAS21M10S0808

8 What is the length of RS?

- A. 8 units
- B. 10 units
- C. $8\sqrt{2}$ units
- D. $\frac{16}{3}\sqrt{3}$ units

SAS21M10S0809

9 What is the value of $\sec(1 - \sin)(\sec + \tan)$?

ABC is an isosceles triangle, with $AB = BC$. A semicircle of the area equal to that of the triangle is combined with it.

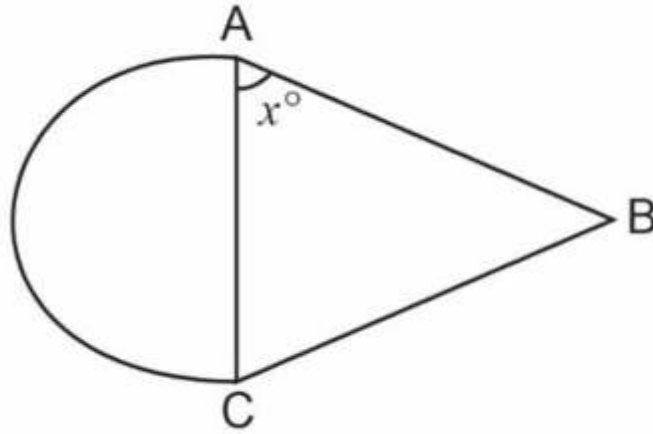

SAS21M10S0810

10 What is the value of $\tan x$?

- A. 1
- B. $\frac{1}{4} \pi$
- C. $\frac{1}{2} \pi$
- D. π

Curriculum Aligned Competency Based Test Items

Mathematics

Class 10 – Chapter 9

Some applications of Trigonometry

At a toll plaza, an electronic toll collection system has been installed. FASTag can be used to pay the fare. The tag can be pasted on the windscreen of a car.

At the toll plaza a tag scanner is placed at a height of 6 m from the ground. The scanner reads the information on the tag of the vehicle and debits the desired toll amount from a linked bank account.

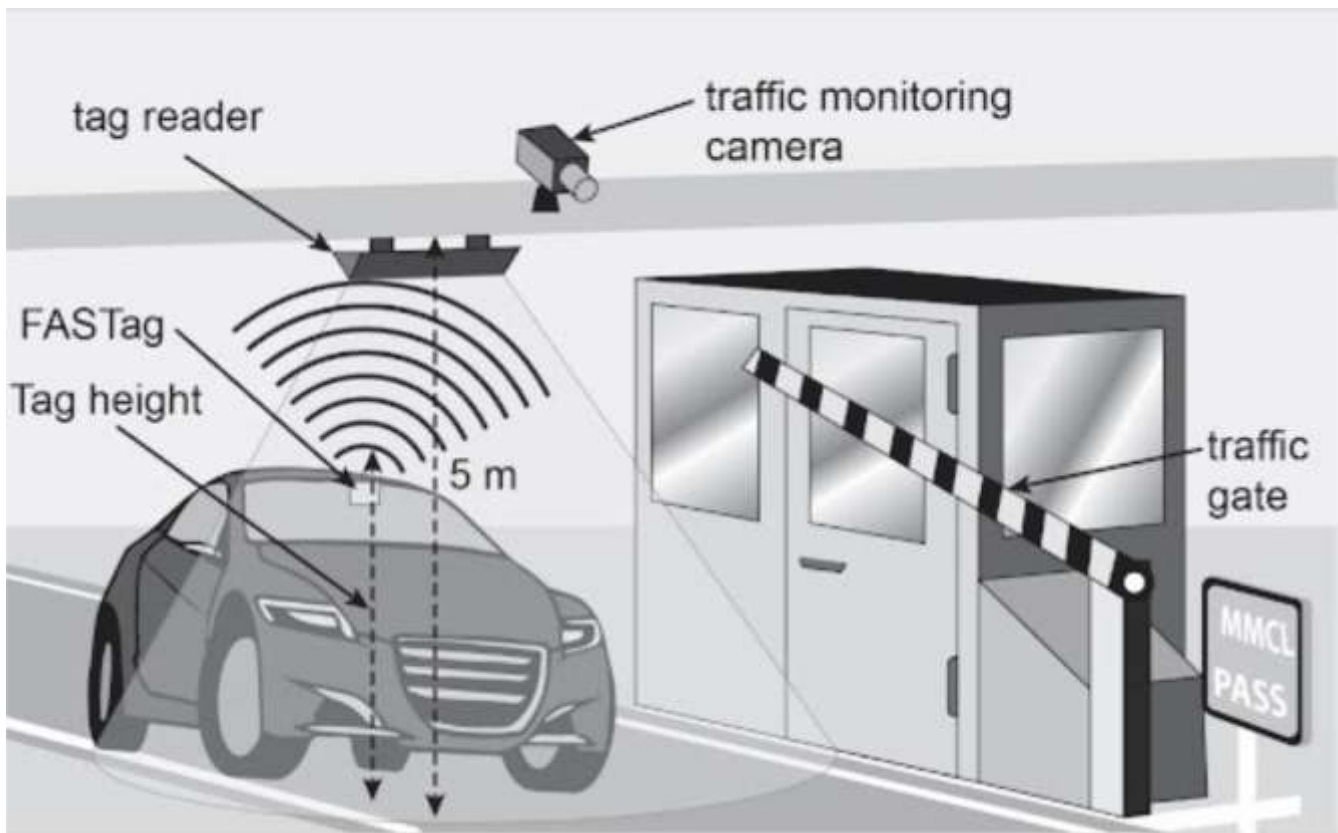

For the tag scanner to function properly the speed of a car needs to be less than 30 km per hour. A car with a tag installed at a height of 1.5 m from the ground enters the scanner zone.

SAS21M10N0901

- 1 The scanner gets activated when the car's tag is at a distance of 5 m from it. Give one trigonometric ratio for the angle between the horizontal and the line between the car tag and the scanner?

SAS21M10N0902

- 2 The scanner reads the complete information on the car's tag while the angle between chip and scanner changes from 30° to 60° due to car movement. What is the distance moved by the car?

- A. $\sqrt{3}$ m
B. $3\sqrt{3}$ m
C. 4.5 m
D. $4.5\sqrt{3}$ m

SAS21M10N0903

- 3 A vehicle with a tag pasted at a height of 2 m from the ground stops in the scanner zone. The scanner reads the data at an angle of 45° . What is the distance between the tag and the scanner?

- A. 2 m
B. 4 m
C. $4\sqrt{2}$ m
D. 8 m

At the toll plaza, a traffic monitoring camera is also installed at a height of 6.2 m. It takes pictures of moving vehicles at regular intervals.

The diagram below shows the position of the camera and a car moving away from it after paying the toll in four instances. The speed of the car is 5 m/s.

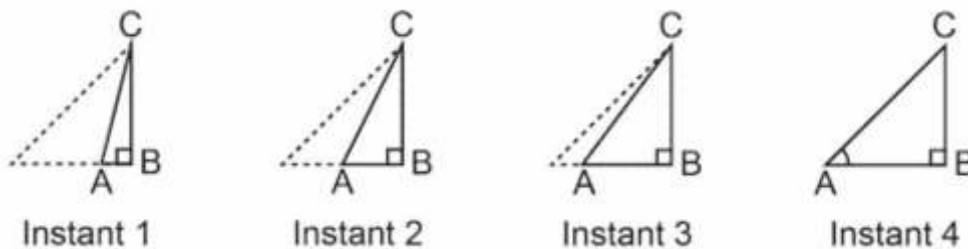

SAS21M10N0904

- 4 The angle made by the camera to the car in instance 1 is 30° and changes to 60° in instance 4. What is the distance moved by the car? ($\sqrt{3} = 1.73$)

SAS21M10N0905

- 5 Seaweed is found under an 80 m deep seafloor. To reach it a diver makes a 45° dive from a boat. What is the distance travelled by the diver to reach the seafloor?

- A. 80 m
- B. 80.2 m
- C. $80\sqrt{2}$ m
- D. $80\sqrt{3}$ m

SAS21M10N0906

- 6 By the time the diver collected seaweed, the boat shifted 20 m on the opposite side. The diver now has to rise at an angle of 60° to reach the boat. What is the distance the diver travels to reach the boat?

Two persons are watching a game in a stadium. The distance between them is 1.5 m.

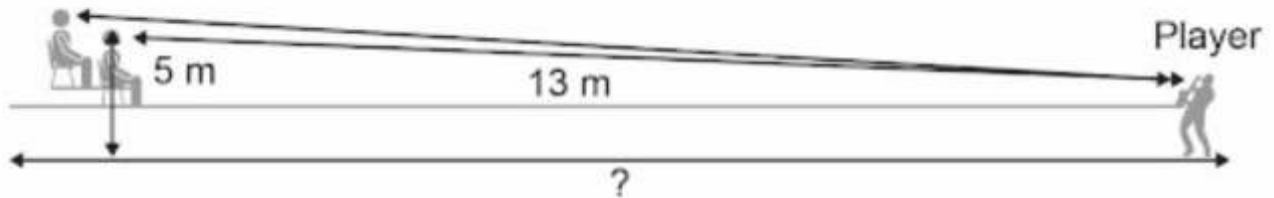

SAS21M10N0907

- 7 What is the distance of the second person from the player?

- A. 10 m
- B. 12 m
- C. 13.5 m
- D. 14.5 m

SAS21M10N0908

- 8 A 9 m high street-light pole is broken during a storm. The top end of the pole touches the ground at 30° . At what height did the pole break?

- A. 3 m
- B. 3.75 m
- C. 4.5 m
- D. 9 m

A triangle is drawn inside a square of side length 6 cm as shown in figure given below.

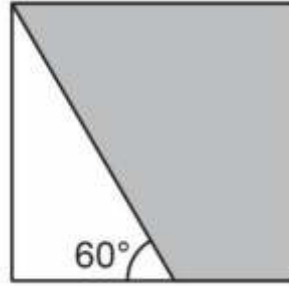

SAS21M10N0909

9 What is the area of the shaded region?

In the figure given below, PQU is a right triangle with $\angle PQU = 90^\circ$. ST is parallel to RQ, PS = RQ and ST = RU. Calculate the length of SR.

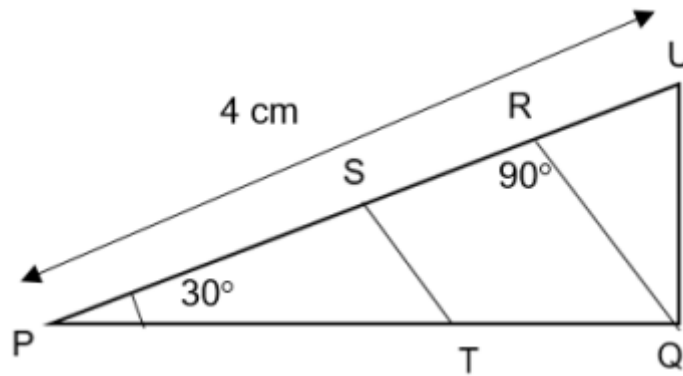

SAS21M10N0910

10 What is the length of SR?

Curriculum Aligned Competency Based Test Items

Mathematics

Class 10 – Chapter 10

Circle

SAS21M10S1001

- 1 Anu says, 'A circle of radius 10 cm can have 100 tangents.'
Is Anu correct? Give a reason to justify your answer.

Here is a circle with centre O.

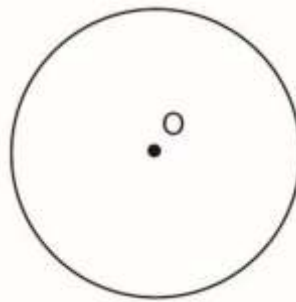

SAS21M10S1002

- 2 Manu wants to draw a tangent RS to the circle.
What is the number of points at which the line RS will meet the circle?

- A. 0
B. 1
C. 2
D. 3

Given below is the diagram of a pair of pulleys.

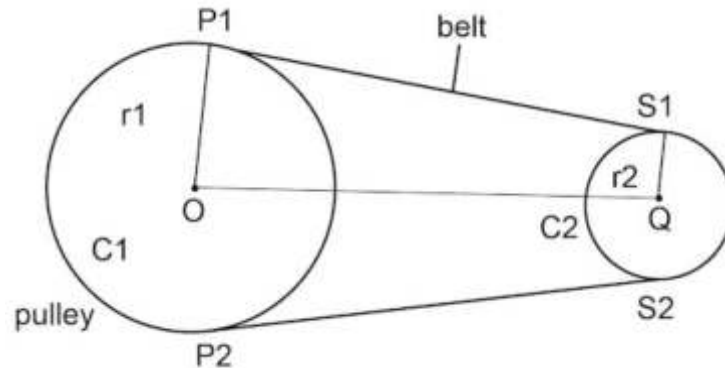

C1 and C2 are two pulleys attached with a belt.

P1 and P2 are points of contact, where the belt meets C1. S1 and S2 are points of contact, where belt meets C2.

O and Q are the centres of C1 and C2, respectively.

SAS21M10S1003

- 3 Identify the common tangents to the two circles (pulleys)?

Ankit joins the centre of the two pulleys and observes line segments P1S1 and P2S2 when extended meet at a point X.

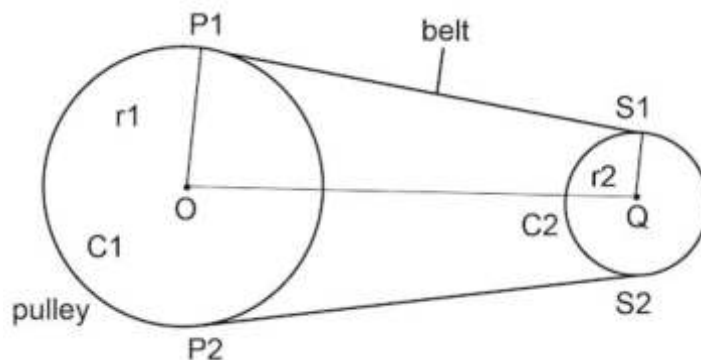

SAS21M10S1004

- 4 What is the length of OX when the diameter of C1 is 30 cm, diameter of C2 is 10 cm and length of OQ is 100 cm?

- A. 33.3 cm
- B. 133.3 cm
- C. 150 cm
- D. 250 cm

SAS21M10S1005

5 Which line segment is equal to the length of P1S1?

- A. OQ
- B. QX
- C. Xs2
- D. P2S2

Given below is the diagram of a pair of pulleys.

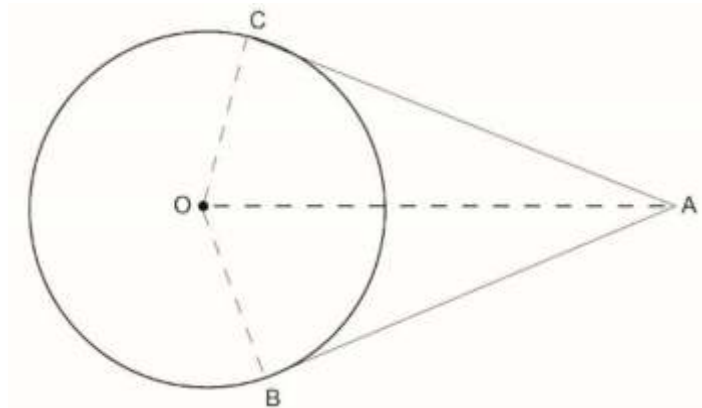

The length of AC is 12 cm.

SAS21M10S1006

6 What is the perimeter of the triangle ABO?

- A. 27 cm
- B. 29 cm
- C. 30 cm
- D. 34 cm

SAS21M10S1007

7 In the given figure, $\angle CAB = 20^\circ$.
What is the measure of $\angle AOC$?

The figure shown below represents a circle with centre O and diameter 12 cm.

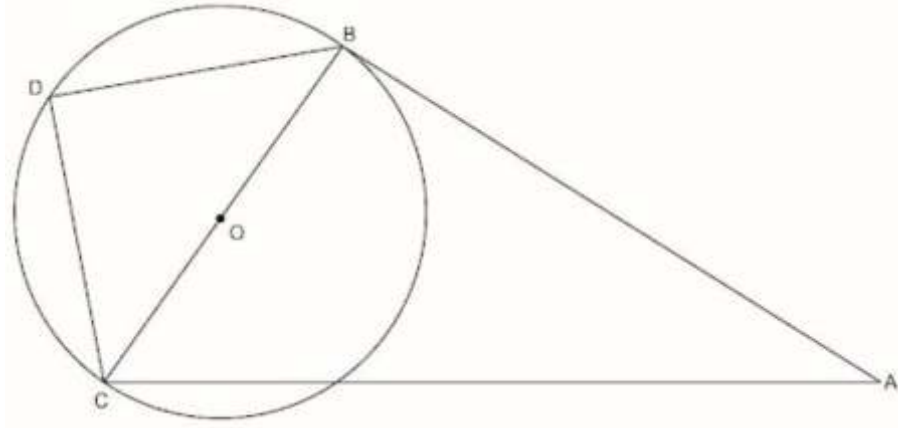

In triangle DBA, $\angle DBC = \angle BCD$ and $\angle A = 50^\circ$.

SAS21M10S1008

8 What is the measure of $\angle DCA$?

- A. 50°
- B. 85°
- C. 100°
- D. 130°

SAS21M10S1009

9 Dhruv said that, "The quadrilateral DBAC is a cyclic quadrilateral." Is Dhruv correct? Give a reason to support your answer.

SAS21M10S1010

10 In triangle BAC, the length of side CA = 2.5 times OB. What is the length of side BA?

Curriculum Aligned Competency Based Test Items

Mathematics

Class 10 – Chapter 11

Constructions

SAS21M10S1101

- 1 Jeenal wants to divide a line segment internally in the ratio $p:q$. What is the least number of equal parts of the line segment Jeenal needs to make to divide the line in the required ratio?

- A. p
- B. q
- C. $p - q$
- D. $p + q$

Here is Jeenal's process to divide a line segment PQ externally in the ratio 4:5.

Step 1: Draw the line segment PQ of the given length.

Step 2: Draw any ray PY.

Step 3: On the ray PY, mark nine arcs of equal length (label the points of intersection A_1, A_2, A_3, A_4 and so on up to A_9).

Step 4: Join the point A_4 to the end point Q of the line segment.

SAS21M10S1102

- 2 What must be Jeenal's next step?

- A. Draw a line parallel to A_4Q from A_1
- B. Draw a line parallel to A_4Q from A_5
- C. Draw a line parallel to A_4Q from A_8
- D. Draw a line parallel to A_4Q from A_9

SAS21M10S1103

- 3 Arush wants to use a protractor to draw a line parallel to A_4Q . He measures $\angle PA_4Q$ as 80° . What is the measure of the angle that Arush must draw to get a line parallel to A_4Q ?

Sarah wants to cut a straw in the ratio 2:3.

She places the straw on her notebook and marks different points on it as shown in the picture.

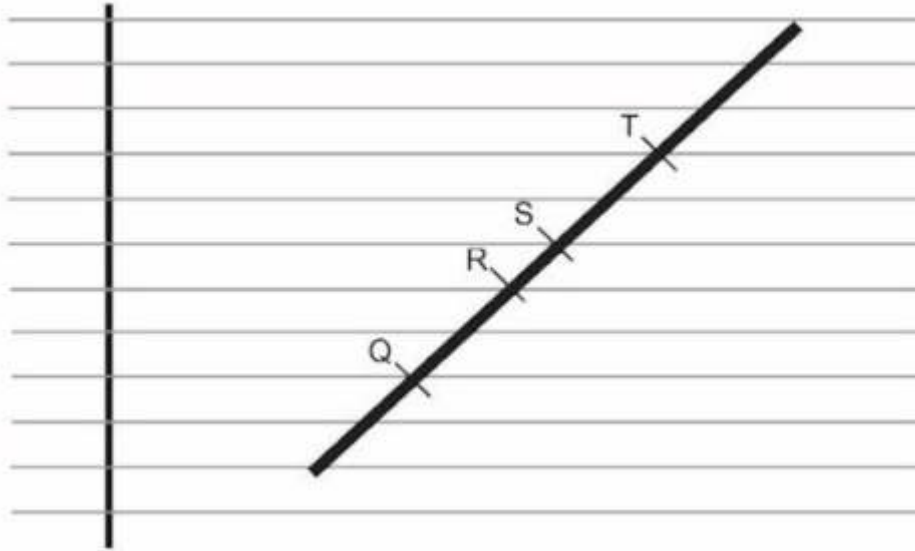

SAS21M10S1104

4 Along which point should she cut the straw to get the desired ratio?

- A. Q
- B. R
- C. S
- D. T

Pawan wants to draw a triangle $AB'C'$ similar to triangle ABC where length of $AB' = \frac{3}{4} AB$.
She does the following

Step 1 – Draw triangle ABC .

Step 2 – Find the point that divides AC internally in the ratio 3:1.

Step 3 – Find the point that divides BC internally in the ratio 3:1.

Step 4 – Join the two points so found.

SAS21M10S1105

5 In which step did Pawan make a mistake?

- A. Step 1
- B. Step 2
- C. Step 3
- D. Step 4

SAS21M10S1106

- 6 Meera constructs a triangle ABC right angled at B whose base and perpendicular are of lengths 6 cm. Then, she constructed a similar triangle A'BC' whose sides are $\frac{2}{3}$ times the corresponding sides of the given triangle. Which of the following shows the measure of all three angles of triangle A'BC'?

- A. $\angle BA'C = 22.5^\circ$, $\angle A'BC' = 135^\circ$ and $\angle A'C'B = 22.5^\circ$
 B. $\angle BA'C' = 45^\circ$, $\angle A'BC' = 90^\circ$ and $\angle A'C'B = 45^\circ$
 C. $\angle BA'C = 60^\circ$, $\angle A'BC' = 60^\circ$ and $\angle C'B = 60^\circ$
 D. $\angle BA'C = 67.5^\circ$, $\angle A'BC' = 45^\circ$ and $\angle A'C'B = 67.5^\circ$

Priyanka finds this piece of a circular disc in her grandma's trunk.



She wants to find the diameter of the disc.

SAS21M10S1107

- 7 What could Priyanka do to find the diameter of the disk?
- A. Find the centre of the inner circle by drawing the diameter and finding its mid-point.
 B. Find the greatest distance between any two points on the boundary of the broken disc found.
 C. Find the point P where rotation of the disc about the point P by 360° gets the disc in the same position.
 D. Draw the perpendicular bisectors of two non-parallel chords to get the centre point and calculate the diameter.

Abhilasha wants to find the radius of a circle. She places a setsquare on the circle as shown below.



SAS21M10S1108

8 Based on the position of the setsquare and the readings shown on the setsquare, what is the diameter of the circle?

- A. 3
- B. 4
- C. 5
- D. 7

Here is a circle with centre O.



SAS21M10S1109

9 She says, “The radius of the circle is 3 cm.”
Explain with reasons why Shrishti is correct.

Pooja does the construction of tangents to a circle from a point outside it as shown below.
Step 1 – Given a circle and a point outside it.

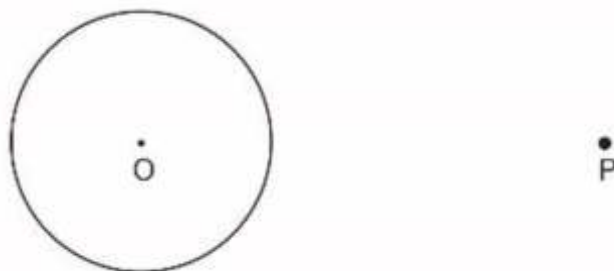

Step 2 – Draw a line from the centre of the circle O to the given point P .

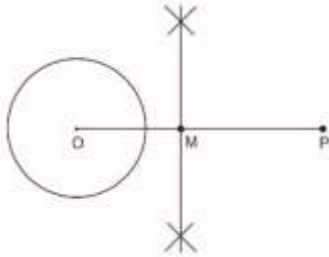
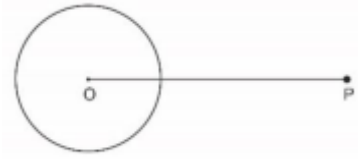

Step 3 – Construct a perpendicular bisector of OP .

Label intersection of OP and the perpendicular bisector as M .
Step 4 – With M as centre and OM as radius, mark an arc across the circle at two points J and K .

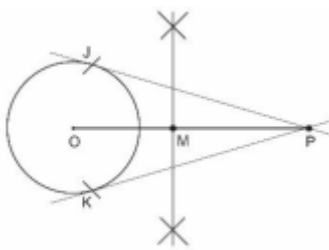
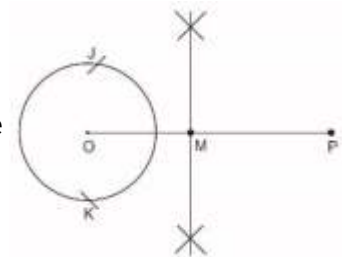

Step 5 - Find the tangents from the point P to the circle by joining JP and KP .

Rajat claims that, in step 2, the perpendicular bisector can still be found using an alternate way. Draw intersecting arcs on one side of OP using the same radius and on the other side of OP with another radius as shown below and join the points of intersection.

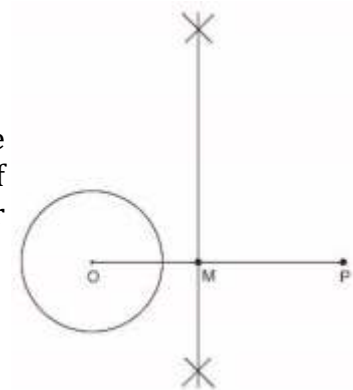

SAS21M10S1110

10 Explain why Rajat is correct.

Curriculum Aligned Competency Based Test Items

Mathematics

Class 10 – Chapter 12

Areas related to Circle

Jaya drew this rangoli design during a competition.

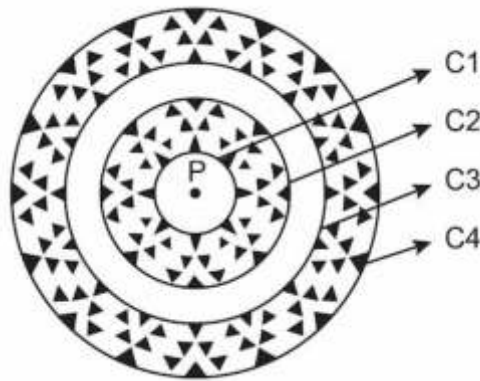

Circles C1, C2, C3 and C4 have common centre P.

The radius of circle C1 is 6 cm.

The table given below shows the radii of circles in terms of the radius of circle C1.

Radius of circle	Times of the radius of C1
C2	2
C3	2.5
C4	3.5

SAS21M10S1201

- 1** The area enclosed between circle C1 and C2 and circle C3 and C4 have been painted. What area of the figure has been painted?

- A. $85 \pi \text{ cm}^2$
- B. $108 \pi \text{ cm}^2$
- C. $324 \pi \text{ cm}^2$
- D. $846 \pi \text{ cm}^2$

SAS21M10S1202

2 Jaya wants to outline the boundaries of circles C2 and C3 with a ribbon. One roll of the ribbon is 20 cm long. How many rolls of ribbon would Jaya need? (Use $\pi = \frac{22}{7}$)

- A. 8
- B. 9
- C. 12
- D. 116

SAS21M10S1203

3 Jaya says, "Since the radius of circle C4 is 3.5 times of the radius of circle C1, the area occupied by circle C4 is 3.5 times the area occupied by circle C1."
Is Jaya correct? Give reason.

A ferris wheel is a rotating upright wheel with multiple passenger cars attached to the rim. The passenger cars are installed at equal distance from each other. Neeraj takes a picture of a Ferris wheel.

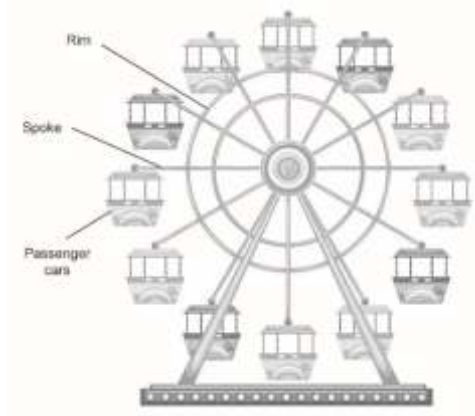

He then makes a drawing of the picture and labels some points to make some calculations as under

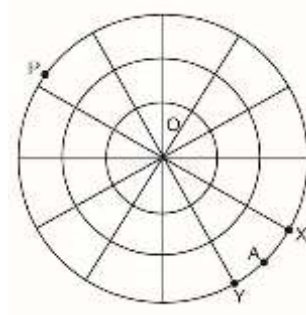

Point X and Y show the position of two consecutive passenger cars. The centre of the wheel is labelled O. The radius of the wheel is 16 m.

SAS21M10S1204

4 What is the measure of angle XOY?

SAS21M10S1205

5 Each sector of the Ferris wheel is to be decorated with lights of different colours. What is the area decorated by each light?

- A. $2.66 \pi \text{ m}^2$
- B. $21.33 \pi \text{ m}^2$
- C. $25.6 \pi \text{ m}^2$
- D. $3072 \pi \text{ m}^2$

SAS21M10S1206

6 What number should the area of sector OYAX be multiplied with to get the area of sector OYPX?

- A. 8
- B. 10
- C. 11
- D. 12

Given below is the diagram of a trapezium enclosed by a circle of radius 3 cm.

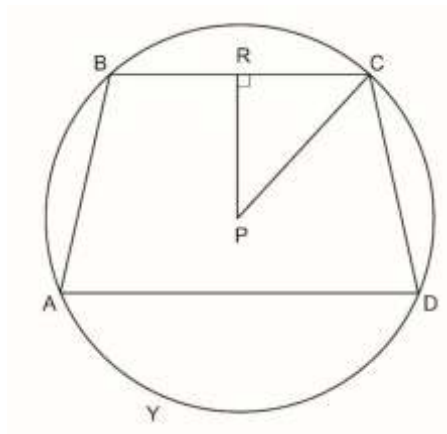

The length of BC is 4 cm.

SAS21M10S1207

7 What is the length of RP?

- A. $\sqrt{5}$ cm
- B. 5 cm
- C. $\sqrt{13}$ cm
- D. 13 cm

SAS21M10S1208

8 The distance between AD and BC is 3.5 cm.
Length of AD is 5.5 cm and length of BC is 4 cm.
What is the area of the circle outside the trapezium? (Use $\pi = \frac{2}{27}$)

In the figure given below, XPY is a semi-circle whose diameter XY = 18 cm and its centre is R.

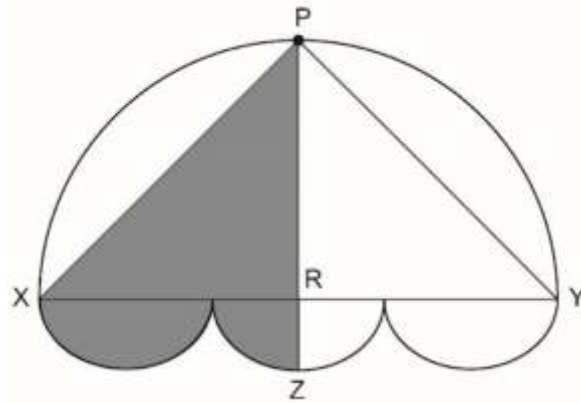

SAS21M10S1209

7 What is the area of shaded region?

- A. $\frac{27\pi + 162}{4}$ cm²
- B. $\frac{27\pi}{4} + 81$ cm²
- C. $\frac{08\pi}{4}$ cm²
- D. $\frac{08\pi}{2}$ cm²

Given below is a geometrical shape.

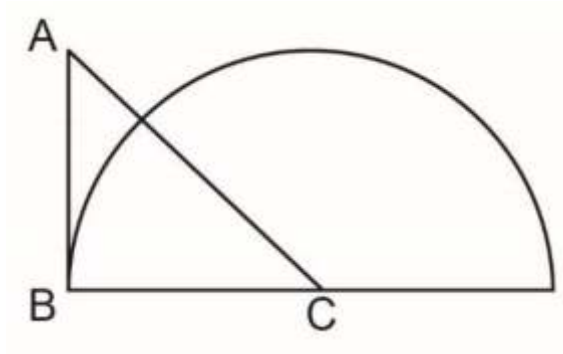

SAS21M10S1210

- 10** C is the centre of the circle with radius $BC = 21$ cm.
ABC is an isosceles right triangle.
Calculate the area of the triangle outside the circular region? (Use $\pi = 3.14$)

Curriculum Aligned Competency Based Test Items

Mathematics

Class 10 – Chapter 13

Surface Area and Volume

An open water tank walls are of thickness 10 cm.

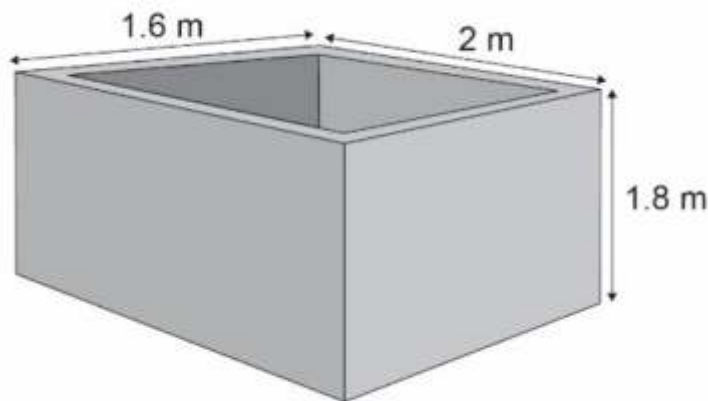

SAS21M10S1301

1 What is the outer surface area of its wall?

SAS21M10S1302

2 Which of the following gives the capacity (in litre) of the tank?

- A. $1.8 \times 1.4 \times 1.6$
- B. $1.9 \times 1.5 \times 1.7$
- C. $2 \times 1.6 \times 1.8$
- D. $2.1 \times 1.7 \times 1.9$

A lid was built to cover the top of the tank.

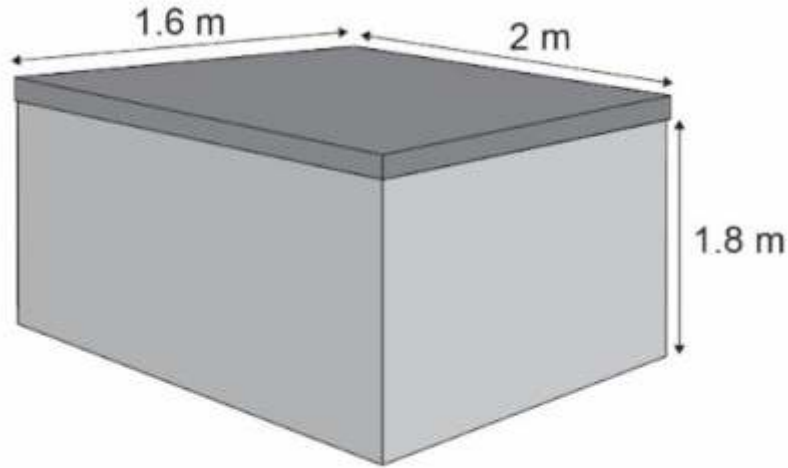

SAS21M10S1303

- 3 The thickness of the lid is 3 cm.
What is the total surface area (in m^2) of the lid?

- A. 3.412
- B. 6.4
- C. 6.62
- D. 19.576

SAS21M10S1304

- 4 The lid is made of cement.
What is the volume of the cement used?

SAS21M10S1305

- 5 The inner surfaces of the tank is covered with square tiles.
The side length of a tile is 10 cm.
How many tiles would be required?

- A. 1296
- B. 1548
- C. 1800
- D. 4032

SAS21M10S1306

6 Water is supplied to a village through a water tanker.

The water tanker is cylindrical in shape with diameter 110 cm and height 118 cm. A total of 30,000 litres of water is supplied through the tanker.

How many times was the water tanker used? (The tanker was always used at full capacity.)
(Use $\pi = 3.14$ and $1\text{m}^3 = 1000$ litres)

This is the picture of a glass flask used in chemistry lab.

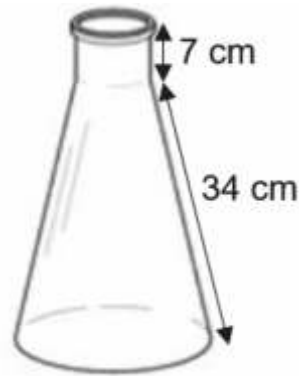

The radius of the upper rim is 3 cm and the radius of the base of the flask is 9 cm.

SAS21M10S1307

7 What is the surface area of the flask?

- A. $429\pi\text{ cm}^2$
- B. $531\pi\text{ cm}^2$
- C. $558\pi\text{ cm}^2$
- D. $582\pi\text{ cm}^2$

SAS21M10S1308

8 For an experiment, water is filled up to the slant height of the flask.
What volume (in cm^3) of the flask is filled with water?

- A. 63π
- B. $135\sqrt{43}\pi$
- C. $192\sqrt{70}\pi$
- D. $(192\sqrt{70}+63)\pi$

A table in a restaurant is in the shape of a hemisphere.

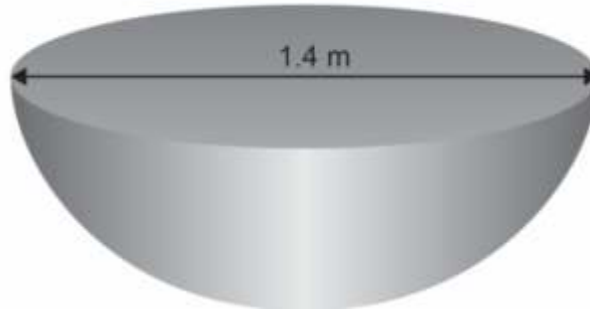

SAS21M10S1309

9 What is the surface area of the table top?

- A. $0.49\pi \text{ m}^2$
- B. $0.98\pi \text{ m}^2$
- C. $1.47\pi \text{ m}^2$
- D. $5.88\pi \text{ m}^2$

SAS21M10S1310

10 The table is made of wood.
What is the volume of the wood used?

- A. $0.343\pi \text{ m}^3$
- B. $0.229\pi \text{ m}^3$
- C. $0.457\pi \text{ m}^3$
- D. $0.829\pi \text{ m}^3$

Curriculum Aligned Competency Based Test Items

Mathematics

Class 10 – Chapter 14

Statistics

Arti owns a manufacturing company. She hires 5 supervisors and 20 operators for a 6-month project. The table given below shows their salary breakup.

Position	Salary for the first two months	Salary for the remaining four months
Supervisor	Between Rs 18,000 to Rs 20,000	Between Rs 22,000 to Rs 25,000
Operator	Between Rs 8,000 to Rs 10,000	Between Rs 13,000 to Rs 15,000

SAS21M10D1401

- 1 The mean salary of the supervisors for the first two months is Rs 19,000. The salary of three supervisors are Rs 18,000, Rs 18,500 and Rs 20,000 respectively. What could be the salary of other two supervisors?

SAS21M10D1402

- 2 Arti agrees to pay the maximum decided amount as salary to the operators. What would be the total amount (in Rs) that Arti will have to pay the operators for the first two months?

- A. Rs 10,000
- B. Rs 200,000
- C. Rs 300,000
- D. Rs 500,000

A table in a restaurant is in the shape of a hemisphere.

Salary (in Rs)	Number of operators
Rs 13,000	5
Rs 13,500	3
Rs 14,000	2
Rs 14,500	4
Rs 15,000	6

SAS21M10D1403

3 What is the median salary of the operators after two months?

- A. Rs 14,000
- B. Rs 14,250
- C. Rs 14,500
- D. Rs 15,000

SAS21M10D1404

4 What is the salary received by most of the operators?

A table in a restaurant is in the shape of a hemisphere.

Claim amount (in hundred dollars)	Number of claims
No claims	368
$> 5 \leq 15$	3
$> 15 \leq 25$	610
$> 25 \leq 35$	1255
$> 35 \leq 45$	1067
$> 45 \leq 55$	555
$> 55 \leq 65$	1280

SAS21M10D1405

5 What is the mean claim amount in dollars?

SAS21M10D1406

6 How many claim requests of up to \$3500 did the company receive?

- A. 1067
- B. 1255
- C. 1865
- D. 2730

SAS21M10D1407

7 What is the modal range of the claim amount in dollars?

The data given below shows the number of people of different age groups visiting a restaurant in a day.

Age group (in years)	Number of people
Under 10	20
Under 20	70
Under 30	120
Under 40	152
Under 50	174
Under 60	189
Under 70	192

SAS21M10D1408

8 Anuj throws a bunch of chalks randomly at the board with all the chalks striking the board. What proportion of the chalks are expected to fall in the triangular region?

- A. Between 10-20
- B. Between 20-30
- C. Between 50-60
- D. Between 60-70

SAS21M10D1409

9 How many people of the age group 40-50 years have visited the restaurant?

- A. 22
- B. 32
- C. 54
- D. 174

SAS21M10D1410

10 What is the median age group of the people who visited the restaurant?

Curriculum Aligned Competency Based Test Items

Mathematics

Class 10 – Chapter 15

Probability

Nishant and Kapil are playing a game of darts.
They use this dart board.

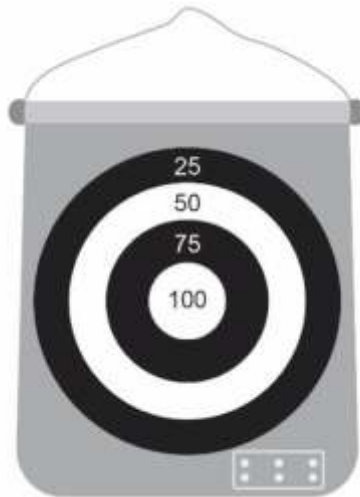

Here are the rules of the game:

When your dart is placed in any circular region, you get the points mentioned in that region.

If your dart strikes outside the circles you get zero points.

During the game all the darts of both Nishant and Kapil fall in the circular region.

The radius of the innermost circle is 7 cm and the width of all other circular regions is 7 cm.

SAS21M10D1501

- 1** Nishant throws the first dart.
What is the probability of Nishant getting a score of 100 in the first throw?

SAS21M10D1502

- 2 Kapil threw a dart which hits the board.
What is the probability of the dart hitting the outermost circular region on the board?

- A. $\frac{1}{4}$
- B. $\frac{4}{5}$
- C. $\frac{7}{16}$
- D. $\frac{9}{16}$

SAS21M10D1503

- 3 In the first three throws Nishant gets 75 points in two throws and 100 points in the third throw.
What is the probability of Nishant getting a 75 in the next throw?

- A. $\frac{1}{2}$
- B. $\frac{2}{3}$
- C. $\frac{3}{4}$
- D. $\frac{3}{16}$

SAS21M10D1504

- 4 Kapil gets 25 points each, in the first and second throws.
How many possibilities are there for the total points Kapil can have after four throws?

- A. 2
- B. 4
- C. 10
- D. 16

This is a paper cup.



Jaya tossed this cup.

When the cup lands on the table, it can land in three possible positions, as shown below.



To calculate the probability of falling in each position, Jaya tosses the cup 60 times. She records her observations in the table below.

Position of cup after toss	Frequency
Inverted	20
upright	5
Rolling side	35

SAS21M10D1505

- 5 Jays tosses the cup one more time.
What would be the probability of the cup falling in the upright position?

- A. $\frac{1}{3}$
B. $\frac{1}{11}$
C. $\frac{1}{12}$
D. $\frac{1}{60}$

Vani does an experiment to see if Jaya is correct in declaring the probability of the cup falling in the upright position.

She tosses a cup many times and plots a graph of her observations as shown below.

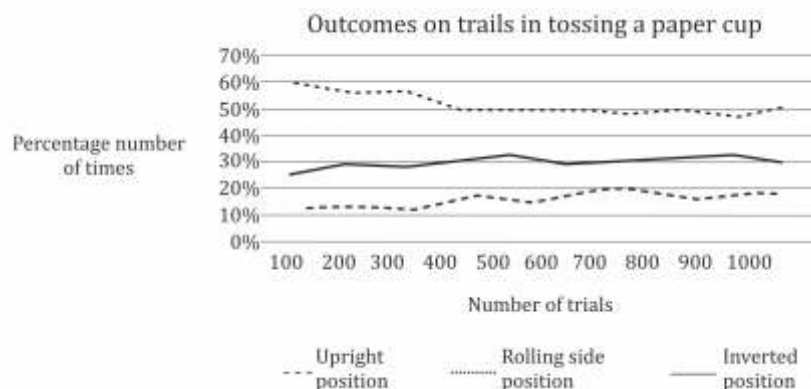

SAS21M10D1506

- 6 Based on the graph and Vani's observations what should be the probability of the cup falling in the upright position if Jaya were to toss the cup again?

In a classroom, a rectangular board is fitted on a wall. The length of the board is 2m and the width of the board is 1m.

Anuj draws this triangle on the board.

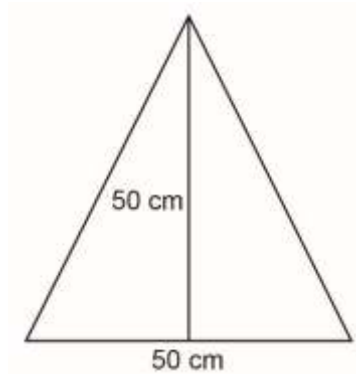

SAS21M10D1507

- 7 Anuj throws a bunch of chalks randomly at the board with all the chalks striking the board. What proportion of the chalks are expected to fall in the triangular region?

SAS21M10D1508

- 8 What is the probability of a chunk of chalk not hitting the board?

- A. 0
- B. $\frac{1}{2}$
- C. $\frac{1}{3}$
- D. 1

Ross observed the food a few puppies preferred to eat.
The table given below shows the number of puppies and their preferred food during day time.

Food	Number of puppies
Egg	10
Meat	20
Milk	7
Pet food	13

SAS21M10D1509

- 9** A puppy was chosen at random from the group that Ross observed.
What is the probability that the chosen puppy prefers to have pet food during the day?

SAS21M10D1510

- 10** Sixty percent of the time, puppies prefers to have the same food at night, which they had eaten during the day.
A puppy ate eggs during the day.
What is the probability that the puppy will not eat eggs at night as well?

Item Number	Question 1
Question Code	SAS21M10C0201
Grade & Chapter Name	Grade 10 Real Numbers
Concept Sub-concept	Numbers Real Numbers (Euclid's Division Lemma)
Competency	Formulate
Item Type	Closed Constructed Response
Full Credit (Full Score)	11
No Credit (No Score)	Any other response or missing response

Item Number	Question 2
Question Code	SAS21M10C0202
Grade & Chapter Name	Grade 10 Real Numbers
Concept Sub-concept	Numbers Real Numbers (Euclid's Division Lemma)
Competency	Employ
Item Type	Closed Constructed Response
Full Credit (Full Score)	Writes that Adya's groups have 12 stamps each and , Sumit's groups have 19 stamps each <ul style="list-style-type: none"> • 12, 19 • 19, 12 • 12 stamps and 19 stamps
Partial Credit (Partial Score)	Correctly mentions the number of stamps in either Adya's or Sumit's groups <ul style="list-style-type: none"> • 11, 19 • 11, 12
No Credit (No Score)	Any other response or missing response

Item Number	Question 3
Question Code	SAS21M10C0203
Grade & Chapter Name	Grade 10 Real Numbers
Concept Sub-concept	Numbers Real Numbers (Euclid's Division Lemma)
Competency	Formulate
Item Type	Closed Constructed Response
Full Credit (Full Score)	22
No Credit (No Score)	Any other response or missing response

Item Number	Question 4
Question Code	SAS21M10Q0104
Grade & Chapter Name	Grade 10 Real Numbers
Concept Sub-concept	Numbers Real Numbers (Euclid's Division Lemma)
Competency	Employ
Item Type	Multiple Choice Question
Full Credit (Full Score)	120
No Credit (No Score)	Any other response or missing response

Item Number	Question 5
Question Code	SAS21M10Q0105
Grade & Chapter Name	Grade 10 Real Numbers
Concept Sub-concept	Numbers Real Numbers (Euclid's Division Lemma)
Competency	Interpret & Evaluate
Item Type	Multiple Choice Question
Full Credit (Full Score)	B. 20
No Credit (No Score)	Any other response or missing response

Item Number	Question 6
Question Code	SAS21M10Q0106
Grade & Chapter Name	Grade 10 Real Numbers
Concept Sub-concept	Numbers Real Numbers (Euclid's Division Lemma)
Competency	Interpret & Evaluate
Item Type	Open Constructed Response
Full Credit (Full Score)	Writes 'Yes' and that the ratio 8:13 is more than 5:19 <ul style="list-style-type: none"> • Yes, $8:13 > 5:19$, thus she had bought more earrings with stones after the price hike
No Credit (No Score)	Any other response or missing response

Item Number	Question 7
Question Code	SAS21M10Q0107
Grade & Chapter Name	Grade 10 Real Numbers
Concept Sub-concept	Numbers Real Numbers (Euclid's Division Lemma)
Competency	Interpret & Evaluate
Item Type	Multiple Choice Question
Full Credit (Full Score)	B. 7
No Credit (No Score)	Any other response or missing response

Item Number	Question 8
Question Code	SAS21M10Q0108
Grade & Chapter Name	Grade 10 Real Numbers
Concept Sub-concept	Numbers Real Numbers (Euclid's Division Lemma)
Competency	Employ
Item Type	Closed Constructed Response
Full Credit (Full Score)	Writes an explanation which predicts the trend For example: <ul style="list-style-type: none"> • The demand for jewelry with stones among customers increases. • People prefer to buy jewelry with stones.
No Credit (No Score)	Any other response or missing response

Item Number	Question 9
Question Code	SAS21M10Q0109
Grade & Chapter Name	Grade 10 Real Numbers
Concept Sub-concept	Numbers Real Numbers (Euclid's Division Lemma)
Competency	Formulate
Item Type	Closed Constructed Response
Full Credit (Full Score)	30% or 30
No Credit (No Score)	Any other response or missing response

Item Number	Question 10
Question Code	SAS21M10Q0110
Grade & Chapter Name	Grade 10 Real Numbers
Concept Sub-concept	Numbers Real Numbers (Euclid's Division Lemma)
Competency	Employ
Item Type	Closed Constructed Response
Full Credit (Full Score)	2057
No Credit (No Score)	Any other response or missing response

Item Number	Question 1
Question Code	SAS21M10C0201
Grade & Chapter Name	Grade 10 Polynomials
Concept Sub-concept	Algebra Algebraic Expressions and Identities (Geometrical Representation)
Competency	Employ
Item Type	Closed Constructed Response
Full Credit (Full Score)	Writes 'No' and mentions that the coordinates of the zero are (0, -2) <ul style="list-style-type: none"> No, coordinates are (0, -2)
No Credit (No Score)	Any other response or missing response

Item Number	Question 2
Question Code	SAS21M10C0202
Grade & Chapter Name	Grade 10 Polynomials
Concept Sub-concept	Algebra Algebraic Expressions and Identities (Geometrical Representation)
Competency	Interpret & Evaluate
Item Type	Multiple Choice Question
Full Credit (Full Score)	C. $p(y) = 0.25y^3 + 0.1y^2 - 0.3y + 1$
No Credit (No Score)	Any other response or missing response

Item Number	Question 3
Question Code	SAS21M10C0203
Grade & Chapter Name	Grade 10 Polynomials
Concept Sub-concept	Algebra Algebraic Expressions and Identities (Geometrical Representation)
Competency	Interpret & Evaluate
Item Type	Open Constructed Response
Full Credit (Full Score)	Describes the effect on the curves of the flower vase <ul style="list-style-type: none"> The curves of the flower pots can be different.
No Credit (No Score)	Any other response or missing response

Item Number	Question 4
Question Code	SAS21M10C0202
Grade & Chapter Name	Grade 10 Polynomials
Concept Sub-concept	Algebra Algebraic Expressions and Identities (Geometrical Representation)
Competency	Interpret & Evaluate
Item Type	Closed Constructed Response
Full Credit (Full Score)	Includes change/decrease/increase and x-axis interception in the answer <ul style="list-style-type: none"> • Change x-axis interceptions • Change constant terms • Change the points where polynomials cut the x-axis • Decrease 1 and increase -1
No Credit (No Score)	Any other response or missing response

Item Number	Question 5
Question Code	SAS21M10C0205
Grade & Chapter Name	Grade 10 Polynomials
Concept Sub-concept	Algebra Algebraic Expressions and Identities (Geometrical Representation)
Competency	Formulate
Item Type	Closed Constructed Response
Full Credit (Full Score)	Finds the volume using dimensions of the cardboard <ul style="list-style-type: none"> • $V = x(30 - 2x)(40 - 2x)$ • $V = 2x^3 - 70x^2 + 600x$
Partial Credit (Partial Score)	Writes the formula for the volume of a cuboid <ul style="list-style-type: none"> • $V = x y z$, where V = volume, x = length, y = breadth, z = height
No Credit (No Score)	Any other response or missing response

Item Number	Question 6
Question Code	SAS21M10C0206
Grade & Chapter Name	Grade 10 Polynomials
Concept Sub-concept	Algebra Algebraic Expressions and Identities (Geometrical Representation)
Competency	Interpret & Evaluate
Item Type	Closed Constructed Response
Full Credit (Full Score)	Writes side lengths should be greater than 0 and less than 10 cm <ul style="list-style-type: none"> • $0 < \text{side length} < 10 \text{ cm}$
No Credit (No Score)	Any other response or missing response

Item Number	Question 7
Question Code	SAS21M10C0207
Grade & Chapter Name	Grade 10 Polynomials
Concept Sub-concept	Algebra Algebraic Expressions and Identities (Geometrical Representation)
Competency	Formulate
Item Type	Closed Constructed Response
Full Credit (Full Score)	1
No Credit (No Score)	Any other response or missing response

Item Number	Question 8
Question Code	SAS21M10C0208
Grade & Chapter Name	Grade 10 Polynomials
Concept Sub-concept	Algebra Algebraic Expressions and Identities (Geometrical Representation)
Competency	Interpret & Evaluate
Item Type	Closed Constructed Response
Full Credit (Full Score)	Writes that the y coordinate keeps on increasing/decreasing indefinitely
No Credit (No Score)	Any other response or missing response

Item Number	Question 9
Question Code	SAS21M10C0209
Grade & Chapter Name	Grade 10 Polynomials
Concept Sub-concept	Algebra Algebraic Expressions and Identities (Relationship between Zeros and Coefficients of a Polynomial)
Competency	Interpret & Evaluate
Item Type	Multiple Choice Question
Full Credit (Full Score)	D. 14
No Credit (No Score)	Any other response or missing response

Item Number	Question 10
Question Code	SAS21M10C0210
Grade & Chapter Name	Grade 10 Polynomials
Concept Sub-concept	Algebra Algebraic Expressions and Identities (Factorisation of Polynomials)
Competency	Employ
Item Type	Closed Constructed Response
Full Credit (Full Score)	$0, \frac{1}{2}, \frac{3}{2}$
Partial Credit (Partial Score)	Any one of these values is missing: $0, \frac{1}{2}, \frac{3}{2}$ For example: <ul style="list-style-type: none"> • $\frac{1}{2}, \frac{3}{24}$ • $0, \frac{1}{2}$ • $0, \frac{3}{2}$
No Credit (No Score)	Any other response or missing response

Item Number	Question 1
Question Code	SAS21M10C0301
Grade & Chapter Name	Grade 10 Pair of Linear Equations in Two Variables
Concept Sub-concept	Algebra Equations (Forming pair of Linear Equations)
Competency	Formulate
Item Type	Closed Constructed Response
Full Credit (Full Score)	Represents the situation with a pair of equations; one showing total expenditure and another relation between expenditure on food and ticket cost. For example: <ul style="list-style-type: none"> • $x = 3y, x + y = 600$ • $y = 13x, x + y = 600$ • $a = 13b, a + b = 600$ • $a = 3b, a + b = 600$ • $x + 3x = 600$
No Credit (No Score)	Any other response or missing response

Item Number	Question 2
Question Code	SAS21M10C0302
Grade & Chapter Name	Grade 10 Pair of Linear Equations in Two Variables
Concept Sub-concept	Algebra Equations (Forming pair of Linear Equations)
Competency	Interpret & Evaluate
Item Type	Closed Constructed Response
Full Credit (Full Score)	₹ 100
No Credit (No Score)	Any other response or missing response

Item Number	Question 3
Question Code	SAS21M10C0303
Grade & Chapter Name	Grade 10 Pair of Linear Equations in Two Variables
Concept Sub-concept	Algebra Equations (Forming pair of Linear Equations)
Competency	Employ
Item Type	Open Constructed Response
Full Credit (Full Score)	Provides reasons which show that the cost difference of ₹ 100 depends on the cost of online versus offline tickets and not on the number of friends <ul style="list-style-type: none"> • Two online and offline ticket difference is constant, i.e., ₹ 100 is independent of group size
No Credit (No Score)	Any other response or missing response

Item Number	Question 4
Question Code	SAS21M10C0304
Grade & Chapter Name	Grade 10 Pair of Linear Equations in Two Variables
Concept Sub-concept	Algebra Equations (Algebraic Methods of Solving a pair of Linear Equations)
Competency	Formulate
Item Type	Multiple Choice Question
Full Credit (Full Score)	B. 120
No Credit (No Score)	Any other response or missing response

Item Number	Question 5
Question Code	SAS21M10C0305
Grade & Chapter Name	Grade 10 Pair of Linear Equations in Two Variables
Concept Sub-concept	Algebra Equations (Graphical Method of Solving a pair of Linear Equations)
Competency	Employ
Item Type	Closed Constructed Response
Full Credit (Full Score)	Mentions that the y-axis represents distance with or without units (in 1,000 nm) and the x-axis represents the number of days
No Credit (No Score)	Any other response or missing response

Item Number	Question 6
Question Code	SAS21M10C0305
Grade & Chapter Name	Grade 10 Pair of Linear Equations in Two Variables
Concept Sub-concept	Algebra Equations (Graphical Method of Solving a pair of Linear Equations)
Competency	Interpret & Evaluate
Item Type	Closed Constructed Response
Full Credit (Full Score)	Accept any number between 8000 and 9000 with or without units nm <ul style="list-style-type: none"> • 8500 nm • 9000
No Credit (No Score)	Any other response or missing response

Item Number	Question 7
Question Code	SAS21M10C0307
Grade & Chapter Name	Grade 10 Pair of Linear Equations in Two Variables
Concept Sub-concept	Algebra Equations (Graphical Method of Solving a pair of Linear Equations)
Competency	Interpret & Evaluate
Item Type	Open Constructed Response
Full Credit (Full Score)	Writes 'No' along and provides a valid reason <ul style="list-style-type: none"> No, a distance-time graph cannot be related to a route map.
No Credit (No Score)	Any other response or missing response

Item Number	Question 8
Question Code	SAS21M10C0308
Grade & Chapter Name	Grade 10 Pair of Linear Equations in Two Variables
Concept Sub-concept	Algebra Equations (Graphical Method of Solving a pair of Linear Equations)
Competency	Interpret & Evaluate
Item Type	Open Constructed Response
Full Credit (Full Score)	Writes a valid reason involving the relation between speed, time and distance <ul style="list-style-type: none"> The cargo ships' speeds differ in the two routes. The westbound cargo ships sail at greater speed. The ocean current helps westbound ships to travel faster.
No Credit (No Score)	Any other response or missing response

Item Number	Question 9
Question Code	SAS21M10C0309
Grade & Chapter Name	Grade 10 Pair of Linear Equations in Two Variables
Concept Sub-concept	Algebra Algebra Equations (Identifying Consistency of pair of Linear Equations)
Competency	Interpret & Evaluate
Item Type	Closed Constructed Response
Full Credit (Full Score)	Writes 'Yes' with an explanation describing the existence of the solution either algebraically or graphically <ul style="list-style-type: none"> Yes, the given pair of linear equations is consistent because it has one solution. Yes, the given pair of linear equations is consistent because they intersect each other.
No Credit (No Score)	Any other response or missing response

Item Number	Question 10
Question Code	SAS21M10C0310
Grade & Chapter Name	Grade 10 Pair of Linear Equations in Two Variables
Concept Sub-concept	Algebra Equations (Algebraic Methods of Solving a pair of Linear Equations)
Competency	Interpret & Evaluate
Item Type	Closed Constructed Response
Full Credit (Full Score)	Writes 'Yes' and provides a valid reason Yes, $x = 3$ and $y = -4$ is the solution for the given pair of linear equations.
No Credit (No Score)	Any other response or missing response

Item Number	Question 1
Question Code	SAS21M10C0401
Grade & Chapter Name	Grade 10 Quadratic Equations
Concept Sub-concept	Algebra Equations (Quadratic Solutions- Factorisation and Completing the Square Method)
Competency	Formulate
Item Type	Multiple Choice Question
Full Credit (Full Score)	B. $h^2 - 200 \times 1800 = 0$
No Credit (No Score)	Any other response or missing response

Item Number	Question 2
Question Code	SAS21M10C0402
Grade & Chapter Name	Grade 10 Quadratic Equations
Concept Sub-concept	Algebra Equations (Quadratic Solutions- Factorisation and Completing the Square Method)
Competency	Interpret & Evaluate
Item Type	Closed Constructed Response
Full Credit (Full Score)	Yes, uses Pythagoras' theorem to form a quadratic equation and solve it to find the positive value of the unknown. <ul style="list-style-type: none"> Yes, let the height of the screen be x. $x^2 + (x + 7)^2 = 13^2$ $2x^2 + 14x + 49 = 169$ $2x^2 + 14x - 120 = 0$ $x^2 + 7x - 60 = 0$ $(x + 12)(x - 5) = 0$ Height cannot be -12. Thus height is 5 inches and width is 12 inches.
No Credit (No Score)	Any other response or missing response

Item Number	Question 3
Question Code	SAS21M10C0403
Grade & Chapter Name	Grade 10 Quadratic Equations
Concept Sub-concept	Algebra Equations (Quadratic Solutions- Factorisation and Completing the Square Method)
Competency	Employ
Item Type	Multiple Choice Question
Full Credit (Full Score)	C. $w^2 - 430w + 15,600$
No Credit (No Score)	Any other response or missing response

Item Number	Question 4
Question Code	SAS21M10C0404
Grade & Chapter Name	Grade 10 Quadratic Equations
Concept Sub-concept	Algebra Equations (Quadratic Solutions- Factorisation and Completing the Square Method)
Competency	Interpret and Evaluate
Item Type	Multiple Choice Question
Full Credit (Full Score)	D. Identifying the nature of the root
No Credit (No Score)	Any other response or missing response

Item Number	Question 5
Question Code	SAS21M10C0405
Grade & Chapter Name	Grade 10 Quadratic Equations
Concept Sub-concept	Algebra Equations (Quadratic Solutions- Factorisation and Completing the Square Method)
Competency	Employ
Item Type	Closed Constructed Response
Full Credit (Full Score)	221 221 tiles
No Credit (No Score)	Any other response or missing response

Item Number	Question 6
Question Code	SAS21M10C0406
Grade & Chapter Name	Grade 10 Quadratic Equations
Concept Sub-concept	Algebra Equations (Quadratic Solutions- Factorisation and Completing the Square Method)
Competency	Interpret & Evaluate
Item Type	Closed Constructed Response
Full Credit (Full Score)	4 4 tiles
No Credit (No Score)	Any other response or missing response

Item Number	Question 7
Question Code	SAS21M10C0407
Grade & Chapter Name	Grade 10 Quadratic Equations
Concept Sub-concept	Algebra Equations (Quadratic Solutions- Factorisation and Completing the Square Method)
Competency	Employ
Item Type	Closed Constructed Response
Full Credit (Full Score)	13.5 13.5 m
No Credit (No Score)	Any other response or missing response

Item Number	Question 8
Question Code	SAS21M10C0408
Grade & Chapter Name	Grade 10 Quadratic Equations
Concept Sub-concept	Algebra Equations (Quadratic Solutions- Factorisation and Completing the Square Method)
Competency	Formulate
Item Type	Multiple Choice Question
Full Credit (Full Score)	D. $1 + \frac{1}{(n+1)}(n^2 - 1)$
No Credit (No Score)	Any other response or missing response

Item Number	Question 9
Question Code	SAS21M10C0409
Grade & Chapter Name	Grade 10 Quadratic Equations
Concept Sub-concept	Algebra Equations (Quadratic Solutions- Factorisation and Completing the Square Method)
Competency	Employ
Item Type	Open Constructed Response
Full Credit (Full Score)	Every beneficiary gets the equal amount.
No Credit (No Score)	Any other response or missing response

Item Number	Question 10
Question Code	SAS21M10C0410
Grade & Chapter Name	Grade 10 Quadratic Equations
Concept Sub-concept	Algebra Equations (Quadratic Solutions- Factorisation and Completing the Square Method)
Competency	Interpret & Evaluate
Item Type	Open Constructed Response
Full Credit (Full Score)	Yes, distribution is fair as every person gets an equal amount along with valid mathematical reasoning. <ul style="list-style-type: none"> • Yes, distribution is fair as every beneficiary gets Rs. n.
No Credit (No Score)	Any other response or missing response

Item Number	Question 1
Question Code	SAS21M10C0501
Grade & Chapter Name	Grade 10 Arithmetic Progressions
Concept Sub-concept	Algebra/Arithmetic Progression Nth term of an AP
Competency	Interpret & Evaluate
Item Type	Multiple Choice Question
Full Credit (Full Score)	B. 7
No Credit (No Score)	Any other response or missing response

Item Number	Question 2
Question Code	SAS21M10C0502
Grade & Chapter Name	Grade 10 Arithmetic Progressions
Concept Sub-concept	Algebra/Arithmetic Progression Nth term of an AP
Competency	Employ
Item Type	Multiple Choice Question
Full Credit (Full Score)	C. 270
No Credit (No Score)	Any other response or missing response

Item Number	Question 3
Question Code	SAS21M10C0503
Grade & Chapter Name	Grade 10 Arithmetic Progressions
Concept Sub-concept	Algebra/Arithmetic Progression Nth term of an AP
Competency	Formulate
Item Type	Closed Constructed Response
Full Credit (Full Score)	Correct answer with unit <ul style="list-style-type: none"> • 10,500 mm • 1050 cm • 10.5 m
No Credit (No Score)	Any other response or missing response

Item Number	Question 4
Question Code	SAS21M10C0504
Grade & Chapter Name	Grade 10 Arithmetic Progressions
Concept Sub-concept	Algebra/Arithmetic Progression Nth term of an AP
Competency	Employ
Item Type	Closed Constructed Response
Full Credit (Full Score)	Correct answer with unit <ul style="list-style-type: none"> • 1,40,000 mm • 14,000 cm • 140 m
No Credit (No Score)	Any other response or missing response

Item Number	Question 5
Question Code	SAS21M10C0505
Grade & Chapter Name	Grade 10 Arithmetic Progressions
Concept Sub-concept	Algebra/Arithmetic Progression Nth term of an AP
Competency	Employ
Item Type	Multiple Choice Question
Full Credit (Full Score)	C. 100 cm
No Credit (No Score)	Any other response or missing response

Item Number	Question 6
Question Code	SAS21M10C0506
Grade & Chapter Name	Grade 10 Arithmetic Progressions
Concept Sub-concept	Algebra/Arithmetic Progression Nth term of an AP
Competency	Interpret & Evaluate
Item Type	Multiple Choice Question
Full Credit (Full Score)	B. 8
No Credit (No Score)	Any other response or missing response

Item Number	Question 7
Question Code	SAS21M10C0507
Grade & Chapter Name	Grade 10 Arithmetic Progressions
Concept Sub-concept	Algebra/Arithmetic Progression Nth term of an AP
Competency	Employ
Item Type	Closed Constructed Response
Full Credit (Full Score)	17 17 chairs
No Credit (No Score)	Any other response or missing response

Item Number	Question 8
Question Code	SAS21M10C0508
Grade & Chapter Name	Grade 10 Arithmetic Progressions
Concept Sub-concept	Algebra/Arithmetic Progression Nth term of an AP
Competency	Employ
Item Type	Closed Constructed Response
Full Credit (Full Score)	Accept both 4 and 5. <ul style="list-style-type: none"> • 4 stacks • 5 stacks
No Credit (No Score)	Any other response or missing response

Item Number	Question 9
Question Code	SAS21M10C0509
Grade & Chapter Name	Grade 10 Arithmetic Progressions
Concept Sub-concept	Algebra/Arithmetic Progression Nth term of an AP
Competency	Interpret & Evaluate
Item Type	Multiple Choice Question
Full Credit (Full Score)	D. $1 \times 2.75 \times 1.55$
No Credit (No Score)	Any other response or missing response

Item Number	Question 10
Question Code	SAS21M10C0510
Grade & Chapter Name	Grade 10 Arithmetic Progressions
Concept Sub-concept	Algebra/Arithmetic Progression Nth term of an AP
Competency	Employ
Item Type	Multiple Choice Question
Full Credit (Full Score)	C. 2, 3, 4
No Credit (No Score)	Any other response or missing response

Item Number	Question 1
Question Code	SAS21M10S0601
Grade & Chapter Name	Grade 10 Triangles
Concept Sub-concept	Geometry/Triangles Pythagoras Theorem
Competency	Employ
Item Type	Multiple Choice Question
Full Credit (Full Score)	B. 8 m
No Credit (No Score)	Any other response or missing response

Item Number	Question 2
Question Code	SAS21M10S0602
Grade & Chapter Name	Grade Triangles
Concept Sub-concept	Geometry/Triangles Pythagoras Theorem
Competency	Employ
Item Type	Multiple Choice Question
Full Credit (Full Score)	C. 30
No Credit (No Score)	Any other response or missing response

Item Number	Question 3
Question Code	SAS21M10S0603
Grade & Chapter Name	Grade 10 Triangles
Concept Sub-concept	Geometry/Triangles Pythagoras Theorem
Competency	Interpret & Evaluate
Item Type	Closed Constructed Response
Full Credit (Full Score)	15,625 15,625 cubic metres 15,625 m ³
No Credit (No Score)	Any other response or missing response

Item Number	Question 4
Question Code	SAS21M10S0604
Grade & Chapter Name	Grade 10 Triangles
Concept Sub-concept	Geometry/Triangles Similarity of Triangles
Competency	Interpret & Evaluate
Item Type	Closed Constructed Response
Full Credit (Full Score)	Similar and explanation includes similarity criteria <ul style="list-style-type: none"> • Mayank, Biju and Shanti had drawn similar triangles as angles in them are of the same measure. • Mayank, Biju and Shanti had drawn similar triangles as sides in them are of the same proportion.
No Credit (No Score)	Any other response or missing response

Item Number	Question 5
Question Code	SAS21M10S0605
Grade & Chapter Name	Grade 10 Triangles
Concept Sub-concept	Geometry/Triangles Similarity of Triangles
Competency	Employ
Item Type	Closed Constructed Response
Full Credit (Full Score)	22.5 22.5 km
No Credit (No Score)	Any other response or missing response

Item Number	Question 6
Question Code	SAS21M10S0606
Grade & Chapter Name	Grade 10 Triangles
Concept Sub-concept	Geometry/Triangles Similarity of Triangles
Competency	Interpret & Evaluate
Item Type	Closed Constructed Response
Full Credit (Full Score)	Yes, with justification involving uniqueness of parallel line in basic proportionality theorem/scale drawing. <ul style="list-style-type: none"> • The length of the road would be the same in all three scale drawings as the line parallel to a side in a triangle and cutting the other two sides in a specific ratio is unique. • Yes, the length of the road is the same as it is a scale drawing.
No Credit (No Score)	Any other response or missing response

Item Number	Question 7
Question Code	SAS21M10S0607
Grade & Chapter Name	Grade 10 Triangles
Concept Sub-concept	Geometry/Triangles Similarity of Triangles
Competency	Formulate
Item Type	Multiple Choice Question
Full Credit (Full Score)	D. RHS
No Credit (No Score)	Any other response or missing response

Item Number	Question 8
Question Code	SAS21M10S0608
Grade & Chapter Name	Grade 10 Triangles
Concept Sub-concept	Geometry/Triangles Similarity of Triangles
Competency	Employ
Item Type	Closed Constructed Response
Full Credit (Full Score)	76.89 sq cm
No Credit (No Score)	Any other response or missing response

Item Number	Question 9
Question Code	SAS21M10S0609
Grade & Chapter Name	Grade 10 Triangles
Concept Sub-concept	Geometry/Triangles Pythagoras Theorem
Competency	Interpret & Evaluate
Item Type	Closed Constructed Response
Full Credit (Full Score)	11.5 11.5 cm 11.53 11.53 cm
No Credit (No Score)	Any other response or missing response

Item Number	Question 10
Question Code	SAS21M10S0610
Grade & Chapter Name	Grade 10 Triangles
Concept Sub-concept	Geometry/Triangles Pythagoras Theorem
Competency	Employ
Item Type	Multiple Choice Question
Full Credit (Full Score)	B. $5\sqrt{3}$ cm
No Credit (No Score)	Any other response or missing response

Item Number	Question 1
Question Code	SAS21M10S0701
Grade & Chapter Name	Grade 10 Coordinate Geometry
Concept Sub-concept	Geometry Coordinate Geometry (Plotting points in the plane)
Competency	Formulate
Item Type	Multiple Choice Question
Full Credit (Full Score)	D. (0, -9)
No Credit (No Score)	Any other response or missing response

Item Number	Question 2
Question Code	SAS21M10S0702
Grade & Chapter Name	Grade 10 Coordinate Geometry
Concept Sub-concept	Geometry Coordinate Geometry (Distance Formula)
Competency	Employ
Item Type	Multiple Choice Question
Full Credit (Full Score)	B. 6 units
No Credit (No Score)	Any other response or missing response

Item Number	Question 3
Question Code	SAS21M10S0703
Grade & Chapter Name	Grade Coordinate Geometry
Concept Sub-concept	Geometry Coordinate Geometry (Plotting points in the plane)
Competency	Interpret & Evaluate
Item Type	Closed Constructed Response
Full Credit (Full Score)	Accept all the answers in which players are not equidistant from each other. <ul style="list-style-type: none"> • Side midfielder and full back • Side midfielder and centre midfielder • Left centre back and left side back
No Credit (No Score)	Any other response or missing response

Item Number	Question 4
Question Code	SAS21M10S0704
Grade & Chapter Name	Grade Coordinate Geometry
Concept Sub-concept	Geometry Coordinate Geometry (Plotting points in the plane)
Competency	Interpret & Evaluate
Item Type	Constructive Response
Full Credit (Full Score)	Right centre back and right side back
No Credit (No Score)	Any other response or missing response

Item Number	Question 5
Question Code	SAS21M10S0705
Grade & Chapter Name	Grade Coordinate Geometry
Concept Sub-concept	Geometry Coordinate Geometry (Finding the area formed by joining points)
Competency	Employ
Item Type	Multiple Choice Question
Full Credit (Full Score)	B. 09 square units
No Credit (No Score)	Any other response or missing response

Item Number	Question 6
Question Code	SAS21M10S0706
Grade & Chapter Name	Grade Coordinate Geometry
Concept Sub-concept	Geometry Coordinate Geometry (Distance Formula)
Competency	Employ
Item Type	Multiple Choice Question
Full Credit (Full Score)	C. 510 units
No Credit (No Score)	Any other response or missing response

Item Number	Question 7
Question Code	SAS21M10S0707
Grade & Chapter Name	Grade Coordinate Geometry
Concept Sub-concept	Geometry Coordinate Geometry (Finding the area formed by joining points)
Competency	Employ
Item Type	Open Constructed Response
Full Credit (Full Score)	(2.5) 2π or equivalent, with or without word square units <ul style="list-style-type: none"> • $(2.5)2\pi$ • 19.63 square units
No Credit (No Score)	Any other response or missing response

Item Number	Question 8
Question Code	SAS21M10S0708
Grade & Chapter Name	Grade Coordinate Geometry
Concept Sub-concept	Geometry Coordinate Geometry (Plotting point in the plane)
Competency	Interpret & Evaluate
Item Type	Closed Constructed Response
Full Credit (Full Score)	Yes, with valid justification. <ul style="list-style-type: none"> • Yes, the point lies within the goal post.
No Credit (No Score)	Any other response or missing response

Item Number	Question 9
Question Code	SAS21M10S0709
Grade & Chapter Name	Grade Coordinate Geometry
Concept Sub-concept	Geometry Coordinate Geometry (Distance Formula)
Competency	Interpret & Evaluate
Item Type	Multiple Choice Question
Full Credit (Full Score)	C. (0, 4)
No Credit (No Score)	Any other response or missing response

Item Number	Question 10
Question Code	SAS21M10S0710
Grade & Chapter Name	Grade 10 Coordinate Geometry
Concept Sub-concept	Geometry Coordinate Geometry (Finding the area formed by joining points)
Competency	Employ
Item Type	Multiple Choice Question
Full Credit (Full Score)	D. 40.5
No Credit (No Score)	Any other response or missing response

Item Number	Question 1
Question Code	SAS21M10S0801
Grade & Chapter Name	Grade 10 Introduction to Trigonometry
Concept Sub-concept	Trigonometry Trigonometric Functions
Competency	Interpret & Evaluate
Item Type	Closed Constructed Response
Full Credit (Full Score)	No, accept answers showing understanding of trigonometric ratio. • All triangles have the same value of $\sin A$. The value of $\sin A$ does not depend on side lengths but is a ratio of the side lengths.
No Credit (No Score)	Any other response or missing response

Item Number	Question 2
Question Code	SAS21M10S0802
Grade & Chapter Name	Grade 10 Introduction to Trigonometry
Concept Sub-concept	Trigonometry Trigonometric Functions
Competency	Employ
Item Type	Multiple Choice Question
Full Credit (Full Score)	B. 1
No Credit (No Score)	Any other response or missing response

Item Number	Question 3
Question Code	SAS21M10S0803
Grade & Chapter Name	Grade 10 Introduction to Trigonometry
Concept Sub-concept	Trigonometry Trigonometric Functions
Competency	Formulate
Item Type	Multiple Choice Question
Full Credit (Full Score)	B. The values of \sin and \cos vary from 0 to 1.
No Credit (No Score)	Any other response or missing response

Item Number	Question 4
Question Code	SAS21M10S0804
Grade & Chapter Name	Grade 10 Introduction to Trigonometry
Concept Sub-concept	Trigonometry Trigonometric Functions
Competency	Interpret & Evaluate
Item Type	Closed Constructed Response
Full Credit (Full Score)	Accept the answers describing increment in the value of $\sin A$ to the maximum value 1. <ul style="list-style-type: none"> The value of $\sin A$ increases as the measure of angle A increases. It reaches to 1 when the person comes directly under the camera.
No Credit (No Score)	Any other response or missing response

Item Number	Question 5
Question Code	SAS21M10S0805
Grade & Chapter Name	Grade 10 Introduction to Trigonometry
Concept Sub-concept	Trigonometry Trigonometric Functions
Competency	Employ
Item Type	Multiple Choice Question
Full Credit (Full Score)	C. $BC = 1$
No Credit (No Score)	Any other response or missing response

Item Number	Question 6
Question Code	SAS21M10S0806
Grade & Chapter Name	Grade 10 Introduction to Trigonometry
Concept Sub-concept	Trigonometry Trigonometric Functions
Competency	Interpret & Evaluate
Item Type	Closed Constructed Response
Full Credit (Full Score)	$\frac{\sqrt{3}}{2}$
No Credit (No Score)	Any other response or missing response

Item Number	Question 7
Question Code	SAS21M10S0807
Grade & Chapter Name	Grade 10 Introduction to Trigonometry
Concept Sub-concept	Trigonometry Trigonometric Functions
Competency	Employ
Item Type	Multiple Choice Question
Full Credit (Full Score)	D. $\frac{4}{3}$
No Credit (No Score)	Any other response or missing response

Item Number	Question 8
Question Code	SAS21M10S0808
Grade & Chapter Name	Grade 10 Introduction to Trigonometry
Concept Sub-concept	Trigonometry Trigonometric Functions
Competency	Employ
Item Type	Multiple Choice Question
Full Credit (Full Score)	D. $\frac{16}{3} \sqrt{3}$ units
No Credit (No Score)	Any other response or missing response

Item Number	Question 9
Question Code	SAS21M10S0809
Grade & Chapter Name	Grade 10 Introduction to Trigonometry
Concept Sub-concept	Trigonometry Trigonometric Functions
Competency	Employ
Item Type	Closed Constructed Response
Full Credit (Full Score)	1
No Credit (No Score)	Any other response or missing response

Item Number	Question 10
Question Code	SAS21M10S0810
Grade & Chapter Name	Grade 10 Introduction to Trigonometry
Concept Sub-concept	Trigonometry Trigonometric Functions
Competency	Interpret & Evaluate
Item Type	Multiple Choice Question
Full Credit (Full Score)	C. $\frac{1}{2}$
No Credit (No Score)	Any other response or missing response

Item Number	Question 1
Question Code	SAS21M10N0901
Grade & Chapter Name	Grade 10 Some Applications of Trigonometry
Concept Sub-concept	Trigonometry Finding Length using trigonometric function
Competency	Interpret & Evaluate
Item Type	Closed Constructed Response
Full Credit (Full Score)	Accept a correct trigonometric ratio in a right triangle using 5 as hypotenuse, 4.5 as height and 4.75 as horizontal distance. <ul style="list-style-type: none"> • $\sin\theta = \frac{9}{10}$ • $\sin\theta = \frac{4.5}{5}$ • $\tan\theta = \frac{4.5}{\sqrt{4.75}}$
No Credit (No Score)	Any other response or missing response

Item Number	Question 2
Question Code	SAS21M10N0902
Grade & Chapter Name	Grade 10 Some Applications of Trigonometry
Concept Sub-concept	Trigonometry Finding Length using trigonometric function
Competency	Employ
Item Type	Multiple Choice Question
Full Credit (Full Score)	B. $3\sqrt{3}$ m
No Credit (No Score)	Any other response or missing response

Item Number	Question 3
Question Code	SAS21M10N0903
Grade & Chapter Name	Grade 10 Some Applications of Trigonometry
Concept Sub-concept	Trigonometry Finding Length using trigonometric function
Competency	Employ
Item Type	Multiple Choice Question
Full Credit (Full Score)	C. $4\sqrt{2}$ m
No Credit (No Score)	Any other response or missing response

Item Number	Question 4
Question Code	SAS21M10N0904
Grade & Chapter Name	Grade 10 Some Applications of Trigonometry
Concept Sub-concept	Trigonometry Finding Length using trigonometric function
Competency	Interpret & Evaluate
Item Type	Open Constructed Response
Full Credit (Full Score)	5.4 5.4 m
No Credit (No Score)	Any other response or missing response

Item Number	Question 5
Question Code	SAS21M10N0905
Grade & Chapter Name	Grade 10 Some Applications of Trigonometry
Concept Sub-concept	Trigonometry Finding Length using trigonometric function
Competency	Employ
Item Type	Multiple Choice Question
Full Credit (Full Score)	C. $80\sqrt{2}$ m
No Credit (No Score)	Any other response or missing response

Item Number	Question 6
Question Code	SAS21M10N0906
Grade & Chapter Name	Grade 10 Some Applications of Trigonometry
Concept Sub-concept	Trigonometry Finding Length using trigonometric function
Competency	Interpret & Evaluate
Item Type	Closed Constructed Response
Full Credit (Full Score)	$160\sqrt{3}$ m 277.1 m
No Credit (No Score)	Any other response or missing response

Item Number	Question 7
Question Code	SAS21M10N0907
Grade & Chapter Name	Grade 10 Some Applications of Trigonometry
Concept Sub-concept	Trigonometry Finding Length using trigonometric function
Competency	Employ
Item Type	Multiple Choice Question
Full Credit (Full Score)	C. 13.5 m
No Credit (No Score)	Any other response or missing response

Item Number	Question 8
Question Code	SAS21M10N0908
Grade & Chapter Name	Grade 10 Some Applications of Trigonometry
Concept Sub-concept	Trigonometry Finding Length using trigonometric function
Competency	Formulate
Item Type	Multiple Choice Question
Full Credit (Full Score)	A. 3 m
No Credit (No Score)	Any other response or missing response

Item Number	Question 9
Question Code	SAS21M10N0909
Grade & Chapter Name	Grade 10 Some Applications of Trigonometry
Concept Sub-concept	Trigonometry Finding Length using trigonometric function
Competency	Employ
Item Type	Closed Constructed Response
Full Credit (Full Score)	$36 - 6\sqrt{3}$ cm ² 25.6 cm ²
No Credit (No Score)	Any other response or missing response

Item Number	Question 10
Question Code	SAS21M10N0910
Grade & Chapter Name	Grade 10 Some Applications of Trigonometry
Concept Sub-concept	Trigonometry Finding Length using trigonometric function
Competency	Formulate
Item Type	Closed Constructed Response
Full Credit (Full Score)	2 cm 2
No Credit (No Score)	Any other response or missing response

Item Number	Question 1
Question Code	SAS21M10S1001
Grade & Chapter Name	Grade 10 Circle
Concept Sub-concept	Geometry Circles(Tangent to a Circle)
Competency	Formulate
Item Type	Closed constructed response
Full Credit (Full Score)	Yes, Anu is correct with valid reasoning. <ul style="list-style-type: none"> • Yes, Anu is correct as a tangent to a circle can be made at any point on the circle and a circle has infinitely many points.
No Credit (No Score)	Any other response or missing response

Item Number	Question 2
Question Code	SAS21M10S1002
Grade & Chapter Name	Grade 10 Circle
Concept Sub-concept	Geometry Circles(Tangent to a Circle)
Competency	Formulate
Item Type	Multiple Choice Question
Full Credit (Full Score)	B. 1
No Credit (No Score)	Any other response or missing response

Item Number	Question 3
Question Code	SAS21M10S1003
Grade & Chapter Name	Grade 10 Circle
Concept Sub-concept	Geometry Circles(Tangent to a Circle)
Competency	Formulate
Item Type	Closed constructed response
Full Credit (Full Score)	P1S1 and P2S2
No Credit (No Score)	Any other response or missing response

Item Number	Question 4
Question Code	SAS21M10S1004
Grade & Chapter Name	Grade 10 Circle
Concept Sub-concept	Geometry Circles(Tangent to a Circle)
Competency	Employ
Item Type	Multiple Choice Question
Full Credit (Full Score)	C. 150 cm
No Credit (No Score)	Any other response or missing response

Item Number	Question 5
Question Code	SAS21M10S1005
Grade & Chapter Name	Grade 10 Circle
Concept Sub-concept	Geometry Circles(Tangent to a Circle)
Competency	Employ
Item Type	Multiple Choice Question
Full Credit (Full Score)	D. P2S2
No Credit (No Score)	Any other response or missing response

Item Number	Question 6
Question Code	SAS21M10S1006
Grade & Chapter Name	Grade Circle
Concept Sub-concept	Geometry Circles(Tangent to a Circle)
Competency	Employ
Item Type	Multiple Choice Question
Full Credit (Full Score)	C. 30 cm
No Credit (No Score)	Any other response or missing response

Item Number	Question 7
Question Code	SAS21M10S1007
Grade & Chapter Name	Grade Circle
Concept Sub-concept	Geometry Circles(Tangent to a Circle)
Competency	Employ
Item Type	Closed constructed response
Full Credit (Full Score)	80° (Using theorem: The tangent at any point of a circle is perpendicular to the radius through the point of contact)
No Credit (No Score)	Any other response or missing response

Item Number	Question 8
Question Code	SAS21M10S1008
Grade & Chapter Name	Grade 10 Circle
Concept Sub-concept	Geometry Circles (Tangent to a Circle)
Competency	Interpret & Evaluate
Item Type	Multiple Choice Question
Full Credit (Full Score)	B. 85°
No Credit (No Score)	Any other response or missing response

Item Number	Question 9
Question Code	SAS21M10S1009
Grade & Chapter Name	Grade 10 Circle
Concept Sub-concept	Geometry Circles(Tangent to a Circle)
Competency	Interpret & Evaluate
Item Type	Closed constructed response
Full Credit (Full Score)	Dhruv is not correct with valid reasoning. <ul style="list-style-type: none"> • No, Dhruv is not correct as the sum of the opposite angles of the quadrilateral DBAC is not 180 degrees. Thus, the quadrilateral DBAC is not a cyclic quadrilateral. • No, Dhruv is not correct as all four corners of the quadrilateral DBCA do not lie on the circle. Thus, the quadrilateral DBAC is not a cyclic quadrilateral.
No Credit (No Score)	Any other response or missing response

Item Number	Question 10
Question Code	SAS21M10S1010
Grade & Chapter Name	Grade 10 Circle
Concept Sub-concept	Geometry Circles(Tangent to a Circle)
Competency	Employ
Item Type	Closed constructed response
Full Credit (Full Score)	18 cm
No Credit (No Score)	Any other response or missing response

Item Number	Question 1
Question Code	SAS21M10S1101
Grade & Chapter Name	Grade 10 Constructions
Concept Sub-concept	Geometry Constructions(a line segment in a given ratio)
Competency	Employ
Item Type	Multiple Choice Question
Full Credit (Full Score)	D. $p + q$
No Credit (No Score)	Any other response or missing response

Item Number	Question 2
Question Code	SAS21M10S1102
Grade & Chapter Name	Grade 10 Constructions
Concept Sub-concept	Geometry Constructions(a line segment in a given ratio)
Competency	Employ
Item Type	Multiple Choice Question
Full Credit (Full Score)	D. Draw a line parallel to A4Q from A9.
No Credit (No Score)	Any other response or missing response

Item Number	Question 3
Question Code	SAS21M10S1103
Grade & Chapter Name	Grade 10 Constructions
Concept Sub-concept	Geometry Constructions(a line segment in a given ratio)
Competency	Employ
Item Type	Closed constructed response
Full Credit (Full Score)	80°
No Credit (No Score)	Any other response or missing response

Item Number	Question 4
Question Code	SAS21M10S1104
Grade & Chapter Name	Grade 10 Constructions
Concept Sub-concept	Geometry Constructions(a line segment in a given ratio)
Competency	Employ
Item Type	Multiple Choice Question
Full Credit (Full Score)	B. R
No Credit (No Score)	Any other response or missing response

Item Number	Question 5
Question Code	SAS21M10S1105
Grade & Chapter Name	Grade 10 Constructions
Concept Sub-concept	Geometry Constructions(a line segment in a given ratio)
Competency	Interpret & Evaluate
Item Type	Multiple Choice Question
Full Credit (Full Score)	C. Step 3
No Credit (No Score)	Any other response or missing response

Item Number	Question 6
Question Code	SAS21M10S1106
Grade & Chapter Name	Grade 10 Constructions
Concept Sub-concept	Geometry Constructions(construct a similar triangle)
Competency	Formulate
Item Type	Multiple Choice Question
Full Credit (Full Score)	B. $\angle BA'C' = 45^\circ$, $\angle A'BC' = 90^\circ$ and $\angle A'C'B = 45^\circ$
No Credit (No Score)	Any other response or missing response

Item Number	Question 7
Question Code	SAS21M10S1107
Grade & Chapter Name	Grade 10 Constructions
Concept Sub-concept	Geometry Construction of Tangents to a Circle
Competency	Employ
Item Type	Multiple Choice Question
Full Credit (Full Score)	D. Draw the perpendicular bisectors of two non-parallel chords to get the centre point and calculate the diameter.
No Credit (No Score)	Any other response or missing response

Item Number	Question 8
Question Code	SAS21M10S1108
Grade & Chapter Name	Grade 10 Constructions
Concept Sub-concept	Geometry Construction of Tangents to a Circle
Competency	Interpret & Evaluate
Item Type	Multiple Choice Question
Full Credit (Full Score)	C. 5
No Credit (No Score)	Any other response or missing response

Item Number	Question 9
Question Code	SAS21M10S1109
Grade & Chapter Name	Grade 10 Constructions
Concept Sub-concept	Geometry Construction of Tangents to a Circle
Competency	Interpret & Evaluate
Item Type	Closed constructed response
Full Credit (Full Score)	Student working should show the following. Setsquare angle = 90° . Angle between radii and tangents at point of contact = 90° . Fourth angle at the centre = 90° (angle sum property of quadrilaterals). Figure obtained by the two radii and tangents is a square (adjacent sides are equal and all angles are 90°).
No Credit (No Score)	Any other response or missing response

Item Number	Question 10
Question Code	SAS21M10S1110
Grade & Chapter Name	Grade 10 Constructions
Concept Sub-concept	Geometry tangents from an external point to a circle
Competency	Interpret & Evaluate
Item Type	Closed constructed response
Full Credit (Full Score)	Student working should show establishment of congruency of triangles to show the line joining the points of intersection of arcs being perpendicular to OP and bisecting OP.
No Credit (No Score)	Any other response or missing response

Item Number	Question 1
Question Code	SAS21M10S1201
Grade & Chapter Name	Grade 10 Areas related to circle
Concept Sub-concept	Geometry/Circles Radius of a circle
Competency	Employ
Item Type	Multiple Choice Question
Full Credit (Full Score)	C. $324 \pi \text{ cm}^2$
No Credit (No Score)	Any other response or missing response

Item Number	Question 2
Question Code	SAS21M10S1202
Grade & Chapter Name	Grade 10 Areas related to circle
Concept Sub-concept	Geometry/Circles Radius of a circle
Competency	Interpret & Evaluate
Item Type	Multiple Choice Question
Full Credit (Full Score)	B. 9
No Credit (No Score)	Any other response or missing response

Item Number	Question 3
Question Code	SAS21M10S1203
Grade & Chapter Name	Grade 10 Areas related to circle
Concept Sub-concept	Geometry/Circles Radius of a circle
Competency	Interpret & Evaluate
Item Type	Closed constructed response
Full Credit (Full Score)	No, with valid reasoning. <ul style="list-style-type: none"> No, Jaya is not correct as the area occupied by circle C1 is 113.14 cm^2 whereas the area occupied by circle C4 is 1386 cm^2 and 1386 is not 3.5 times 113.14.
No Credit (No Score)	Any other response or missing response

Item Number	Question 4
Question Code	SAS21M10S1204
Grade & Chapter Name	Grade 10 Areas related to circle
Concept Sub-concept	Geometry/Circles Angle with degree of a circle
Competency	Employ
Item Type	Closed constructed response
Full Credit (Full Score)	30°
No Credit (No Score)	Any other response or missing response

Item Number	Question 5
Question Code	SAS21M10S1205
Grade & Chapter Name	Grade 10 Areas related to circle
Concept Sub-concept	Geometry/Circles Area of circle
Competency	Employ
Item Type	Multiple Choice Question
Full Credit (Full Score)	B. 21.33π m ²
No Credit (No Score)	Any other response or missing response

Item Number	Question 6
Question Code	SAS21M10S1206
Grade & Chapter Name	Grade 10 Areas related to circle
Concept Sub-concept	Geometry/Circles Area of circle
Competency	Interpret & Evaluate
Item Type	Multiple Choice Question
Full Credit (Full Score)	C. 11
No Credit (No Score)	Any other response or missing response

Item Number	Question 7
Question Code	SAS21M10S1207
Grade & Chapter Name	Grade 10 Areas related to circle
Concept Sub-concept	Geometry/Circles Length of an arc of a sector of a circle
Competency	Employ
Item Type	Multiple Choice Question
Full Credit (Full Score)	A. 5 cm
No Credit (No Score)	Any other response or missing response

Item Number	Question 8
Question Code	SAS21M10S1208
Grade & Chapter Name	Grade 10 Areas related to circle
Concept Sub-concept	Geometry/Circles Area of a circle
Competency	Employ
Item Type	Closed constructed response
Full Credit (Full Score)	Any value between 11.375 and 12.
No Credit (No Score)	Any other response or missing response

Item Number	Question 9
Question Code	SAS21M10S1209
Grade & Chapter Name	Grade 10 Areas related to circle
Concept Sub-concept	Geometry/Circles Area of segment of a circle
Competency	Employ
Item Type	Multiple Choice Question
Full Credit (Full Score)	Option A. $27\pi+1624$ cm ²
No Credit (No Score)	Any other response or missing response

Item Number	Question 10
Question Code	SAS21M10S1210
Grade & Chapter Name	Grade 10 Areas related to circle
Concept Sub-concept	Geometry/Circles Area of segment of a circle
Competency	Employ
Item Type	Closed constructed response
Full Credit (Full Score)	Any value between 47 and 47.4075.
No Credit (No Score)	Any other response or missing response

Item Number	Question 1
Question Code	SAS21M10S1301
Grade & Chapter Name	Grade 10 Surface Area and Volume
Concept Sub-concept	Mensuration Surface Area and Volume of Cuboid
Competency	Employ
Item Type	Closed constructed response
Full Credit (Full Score)	12.96 12.96 m ² 12.96 square m 12.96 square metre
No Credit (No Score)	Any other response or missing response

Item Number	Question 2
Question Code	SAS21M10S1302
Grade & Chapter Name	Grade 10 Surface Area and Volume
Concept Sub-concept	Mensuration Surface Area and Volume of Cuboid
Competency	Formulate
Item Type	Multiple Choice Question
Full Credit (Full Score)	A. $1.8 \times 1.4 \times 1.6$
No Credit (No Score)	Any other response or missing response

Item Number	Question 3
Question Code	SAS21M10S1303
Grade & Chapter Name	Grade 10 Surface Area and Volume
Concept Sub-concept	Mensuration Surface Area and Volume of Cuboid
Competency	Employ
Item Type	Multiple Choice Question
Full Credit (Full Score)	C. 6.62
No Credit (No Score)	Any other response or missing response

Item Number	Question 4
Question Code	SAS21M10S1304
Grade & Chapter Name	Grade 10 Surface Area and Volume
Concept Sub-concept	Mensuration Surface Area and Volume of Cuboid
Competency	Employ
Item Type	Closed constructed response
Full Credit (Full Score)	0.096 m ³ 0.096 cubic m 0.096 cubic metre 96,000 cm ³ 96,000 cubic cm 0.096 cubic centimetre
No Credit (No Score)	Any other response or missing response

Item Number	Question 5
Question Code	SAS21M10S1305
Grade & Chapter Name	Grade 10 Surface Area and Volume
Concept Sub-concept	Mensuration Surface Area and Volume of Cuboid
Competency	Interpret & Evaluate
Item Type	Multiple Choice Question
Full Credit (Full Score)	B. 1616
No Credit (No Score)	Any other response or missing response

Item Number	Question 6
Question Code	SAS21M10S1306
Grade & Chapter Name	Grade 10 Surface Area and Volume
Concept Sub-concept	Mensuration Surface Area and Volume of a Cylinder
Competency	Interpret & Evaluate
Item Type	Closed constructed response
Full Credit (Full Score)	26 27
No Credit (No Score)	Any other response or missing response

Item Number	Question 7
Question Code	SAS21M10S1307
Grade & Chapter Name	Grade 10 Surface Area and Volume
Concept Sub-concept	Mensuration Surface Area and Volume of a Combination of Solids
Competency	Employ
Item Type	Multiple Choice Question
Full Credit (Full Score)	B. 531π cm ²
No Credit (No Score)	Any other response or missing response

Item Number	Question 8
Question Code	SAS21M10S1308
Grade & Chapter Name	Grade 10 Surface Area and Volume
Concept Sub-concept	Mensuration Surface Area and Volume of a Combination of Solids
Competency	Interpret & Evaluate
Item Type	Multiple Choice Question
Full Credit (Full Score)	C. $156\sqrt{70}\pi$
No Credit (No Score)	Any other response or missing response

Item Number	Question 9
Question Code	SAS21M10S1309
Grade & Chapter Name	Grade 10 Surface Area and Volume
Concept Sub-concept	Mensuration Surface Area and Volume of Hemisphere
Competency	Employ
Item Type	Multiple Choice Question
Full Credit (Full Score)	A. 0.49π m ²
No Credit (No Score)	Any other response or missing response

Item Number	Question 10
Question Code	SAS21M10S1310
Grade & Chapter Name	Grade 10 Surface Area and Volume
Concept Sub-concept	Mensuration Surface Area and Volume of Hemisphere
Competency	Employ
Item Type	Multiple Choice Question
Full Credit (Full Score)	B. 0.229π m ³
No Credit (No Score)	Any other response or missing response

Item Number	Question 1
Question Code	SAS21M10D1401
Grade & Chapter Name	Grade 10 Statistics
Concept Sub-concept	Statistics and Probability Statistics (Arithmetic Mean)
Competency	Interpret & Evaluate
Item Type	Closed constructed response
Full Credit (Full Score)	Accept any two combination between Rs 18,000 to Rs 20,000 which gives a sum of Rs 38,500. Rs 19,250 for each supervisor Rs 19,500 and Rs 19,000 Rs 18,500 and Rs 20,000
No Credit (No Score)	Any other response or missing response

Item Number	Question 2
Question Code	SAS21M10D1402
Grade & Chapter Name	Grade 10 Statistics
Concept Sub-concept	Statistics and Probability Statistics (Arithmetic Mean)
Competency	Employ
Item Type	Multiple Choice question
Full Credit (Full Score)	B. Rs 200,000
No Credit (No Score)	Any other response or missing response

Item Number	Question 3
Question Code	SAS21M10D1403
Grade & Chapter Name	Grade 10 Statistics
Concept Sub-concept	Statistics and Probability Statistics (Median)
Competency	Employ
Item Type	Multiple Choice question
Full Credit (Full Score)	B. Rs 14,250
No Credit (No Score)	Any other response or missing response

Item Number	Question 4
Question Code	SAS21M10D1404
Grade & Chapter Name	Grade 10 Statistics
Concept Sub-concept	Statistics and Probability Statistics (Mode)
Competency	Employ
Item Type	Closed constructed response
Full Credit (Full Score)	Rs 15,000
No Credit (No Score)	Any other response or missing response

Item Number	Question 5
Question Code	SAS21M10D1405
Grade & Chapter Name	Grade 10 Statistics
Concept Sub-concept	Statistics and Probability Statistics (Arithmetic Mean)
Competency	Employ
Item Type	Closed constructed response
Full Credit (Full Score)	3428 34.28 hundred dollars
No Credit (No Score)	Any other response or missing response

Item Number	Question 6
Question Code	SAS21M10D1406
Grade & Chapter Name	Grade 10 Statistics
Concept Sub-concept	Statistics and Probability Statistics (Cumulative frequency distribution)
Competency	Employ
Item Type	Multiple Choice Question
Full Credit (Full Score)	D. 3098
No Credit (No Score)	Any other response or missing response

Item Number	Question 7
Question Code	SAS21M10D1407
Grade & Chapter Name	Grade 10 Statistics
Concept Sub-concept	Statistics and Probability Statistics (Mode)
Competency	Employ
Item Type	Closed constructed response
Full Credit (Full Score)	$>55 \leq 65$
No Credit (No Score)	Any other response or missing response

Item Number	Question 8
Question Code	SAS21M10D1408
Grade & Chapter Name	Grade 10 Statistics
Concept Sub-concept	Statistics and Probability Statistics (Cumulative frequency distribution)
Competency	Formulate
Item Type	Multiple Choice Question
Full Credit (Full Score)	D. Between 60-70
No Credit (No Score)	Any other response or missing response

Item Number	Question 9
Question Code	SAS21M10D1409
Grade & Chapter Name	Grade 10 Statistics
Concept Sub-concept	Statistics and Probability Statistics (Cumulative frequency distribution)
Competency	Employ
Item Type	Multiple Choice Question
Full Credit (Full Score)	A. 22
No Credit (No Score)	Any other response or missing response

Item Number	Question 10
Question Code	SAS21M10D1410
Grade & Chapter Name	Grade 10 Statistics
Concept Sub-concept	Statistics and Probability Statistics (Cumulative frequency distribution)
Competency	Employ
Item Type	Closed constructed response
Full Credit (Full Score)	20-30 years
No Credit (No Score)	Any other response or missing response

Item Number	Question 1
Question Code	SAS21M10D1501
Grade & Chapter Name	Grade 10 Probability
Concept Sub-concept	Statistics and Probability Probability (Theoretical Probability)
Competency	Employ
Item Type	Closed constructed response
Full Credit (Full Score)	<ul style="list-style-type: none"> • $\frac{1}{16}$ • 0.062 • $\frac{7^2}{28^2}$ • $\frac{7\pi^2}{28\pi^2}$
No Credit (No Score)	Any other response or missing response

Item Number	Question 2
Question Code	SAS21M10D1502
Grade & Chapter Name	Grade 10 Probability
Concept Sub-concept	Statistics and Probability Probability (Theoretical Probability)
Competency	Employ
Item Type	Multiple Choice Question
Full Credit (Full Score)	$\frac{7}{16}$
No Credit (No Score)	Any other response or missing response

Item Number	Question 3
Question Code	SAS21M10D1504
Grade & Chapter Name	Grade 10 Probability
Concept Sub-concept	Statistics and Probability Probability (Theoretical Probability)
Competency	Interpret & Evaluate
Item Type	Multiple Choice Question
Full Credit (Full Score)	$\frac{3}{16}$
No Credit (No Score)	Any other response or missing response

Item Number	Question 4
Question Code	SAS21M10D1504
Grade & Chapter Name	Grade 10 Probability
Concept Sub-concept	Statistics and Probability Probability (Theoretical Probability)
Competency	Interpret & Evaluate
Item Type	Multiple Choice Question
Full Credit (Full Score)	C. 10
No Credit (No Score)	Any other response or missing response

Item Number	Question 5
Question Code	SAS21M10D1505
Grade & Chapter Name	Grade 10 Probability
Concept Sub-concept	Statistics and Probability Probability (Theoretical Probability)
Competency	Formulate
Item Type	Multiple Choice Question
Full Credit (Full Score)	$\frac{1}{12}$
No Credit (No Score)	Any other response or missing response

Item Number	Question 6
Question Code	SAS21M10D1506
Grade & Chapter Name	Grade 10 Probability
Concept Sub-concept	Statistics and Probability Probability (Theoretical Probability)
Competency	Interpret & Evaluate
Item Type	Closed constructed response
Full Credit (Full Score)	0.2
No Credit (No Score)	Any other response or missing response

Item Number	Question 7
Question Code	SAS21M10D1507
Grade & Chapter Name	Grade 10 Probability
Concept Sub-concept	Statistics and Probability Probability (Theoretical Probability)
Competency	Employ
Item Type	Closed constructed response
Full Credit (Full Score)	$\frac{1}{16}$
No Credit (No Score)	Any other response or missing response

Item Number	Question 8
Question Code	SAS21M10D1508
Grade & Chapter Name	Grade 10 Probability
Concept Sub-concept	Statistics and Probability Probability (Theoretical Probability)
Competency	Interpret & Evaluate
Item Type	Multiple Choice Question
Full Credit (Full Score)	A. 0
No Credit (No Score)	Any other response or missing response

Item Number	Question 9
Question Code	SAS21M10D1509
Grade & Chapter Name	Grade 10 Probability
Concept Sub-concept	Statistics and Probability Probability (Theoretical Probability)
Competency	Interpret & Evaluate
Item Type	Closed constructed response
Full Credit (Full Score)	$\frac{13}{50}$
No Credit (No Score)	Any other response or missing response

Item Number	Question 10
Question Code	SAS21M10D1510
Grade & Chapter Name	Grade1 10 Probability
Concept Sub-concept	Statistics and Probability Probability (Theoretical Probability)
Competency	Employ
Item Type	Closed constructed response
Full Credit (Full Score)	0.4 40%
No Credit (No Score)	Any other response or missing response